

SIX-CHANNEL DOLBY AC3/MPEG2 AUDIO DECODER

PRELIMINARY DATA

FEATURES

- Single chip multi-function audio decoder able to decompress DOLBY AC-3, MPEG-1 and MPEG-2 audio streams.
- Maximum 5.1 channel DOLBY AC-3 decoding to 2 channel mixed down output with DOLBY surround compatible or karaoke capable option.
- Variable bit rate MPEG-1 layer II audio decoding, and MPEG-2 multi-channel audio decoding for karaoke capable application.
- Input data rates
 - up to 448 Kbits/s for AC-3 decoder
 - up to 912 Kbits/s for MPEG-1 or MPEG-2 audio decoder
- Supports up to 8 channel DVD linear PCM input at max rate of 6.144 Mbits/s down-mixing and/or sub-sampling to 2 to 6 channels.
- Accepts MPEG-1 or DVD/MPEG-2 PES input packets.
- Programmable D950 core
- System time clock provides A/V synchronization and PTS packet extraction.
- Automatic error concealment on CRC or synchronization error.
- 6 channel PCM audio output at 16/18/20/24 bit. Sampling rate of 32/44.1/48/96 kHz.
- Two on-chip PLLs providing full circuit operation with only one external 27 MHz clock.
- I²C interface for host control
- Multi-format i²S serial data input port and decoded audio PCM output port.
- IEC-958 (S/PDIF) formatter and transmitter for DOLBY AC-3, MPEG audio bit stream, or audio PCM.
- Dedicated hardware for emulation and test, IEEE 1149.1 (JTAG).
- 3.3V power supply, I/O's 5V tolerant, 0.35μM HCMOS6 technology.
- 160 pin PQFP package

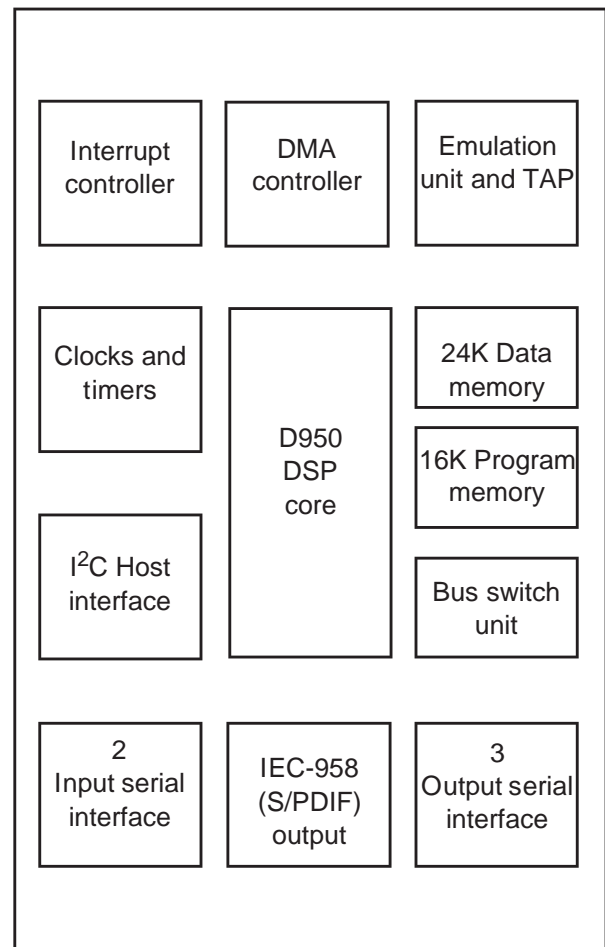

APPLICATIONS

- Digital video disc (DVD) player
- Digital TV (DBS/DVB) receiver
- PC multimedia
- Consumer digital audio

Table of Contents

1	INTRODUCTION	5
2	PIN DESCRIPTIONS	7
3	FUNCTIONAL OVERVIEW	12
4	HOST INTERFACE	16
4.1	HOST INTERFACE REGISTERS	16
4.2	LIST OF HOST COMMANDS	19
5	INPUT SERIAL INTERFACE	25
5.1	INPUT SERIAL INTERFACE REGISTERS	25
5.2	INPUT FIFO	27
5.2.1	Input FIFO registers	27
6	INPUT AND OUTPUT BUFFERS	29
6.1	INPUT BUFFER	29
6.2	OUTPUT BUFFER	29
6.2.1	Input and output buffer registers	29
7	OUTPUT SERIAL INTERFACE - PCM OUTPUT	31
7.1	OUTPUT SERIAL INTERFACE REGISTERS	31
8	INTERRUPT CONTROLLER	34
8.1	INTERRUPT CONTROLLER REGISTERS	35
9	DMA CONTROLLER	40
9.1	DMA OPERATION	40
9.2	DMA REGISTERS	41
9.2.1	Address registers	41
9.2.2	Counting registers	41
9.2.3	Control registers	42
10	IEC-958 TRANSMITTER	44
10.1	IEC-958 TRANSMITTER REGISTERS	44
11	MEMORY	46
11.1	INTERNAL MEMORY RESOURCE	46
11.2	I-MEMORY BUS EXTENSION - DIRECT AND THROUGH BSU	47
11.3	X-MEMORY BUS EXTENSION - DIRECT AND THROUGH BSU	47
11.4	Y-MEMORY BUS EXTENSION THROUGH BSU	47
12	BUS SWITCH UNIT	48
12.1	BSU CONTROL REGISTERS	48
13	CLOCKS AND TIMERS UNIT	51
13.1	OPERATION	51

Table of Contents

13.1.1	Audio clock prescaler	51
13.2	CLOCKS AND TIMERS REGISTERS	52
14	JTAG IEEE 1149.1 TEST ACCESS PORT	55
15	EMULATION UNIT	56
16	D950CORE	58
16.1	D950CORE REGISTERS	60
17	Y SPACE MEMORY MAPPING	61
17.1	MEMORY MAP	61
17.2	CLOCKS AND TIMERS REGISTERS	62
17.3	IEC-958 TRANSMITTER (S/PDIF OUTPUT) REGISTERS	63
17.4	PCM REGISTERS	63
17.5	INPUT/OUTPUT BUFFER REGISTERS	63
17.6	SERIAL INPUT 1 REGISTERS	64
17.7	SERIAL INPUT 0 REGISTERS	64
17.8	HOST INTERFACE REGISTERS	64
17.9	BUS SWITCH UNIT REGISTERS	64
17.10	PLL REGISTERS	65
17.11	DMA CONTROLLER REGISTERS	65
17.12	INTERRUPT CONTROLLER REGISTERS	66
17.13	D950 CORE CONTROL REGISTERS	66
17.14	DATA AND PROGRAM MEMORY MAPPING	67
18	ELECTRICAL SPECIFICATIONS	68
18.1	DC ABSOLUTE MAXIMUM RATINGS	68
18.2	DC ELECTRICAL CHARACTERISTICS	68
18.3	AC CHARACTERISTICS	69
18.3.1	Clocks electrical characteristics	72
18.3.2	E-bus (I direct extension)	73
18.3.3	E-bus (X direct extension)	74
18.3.4	E-bus (I BSU)	75
18.3.5	E-bus (X BSU)	76
18.3.6	E-bus (Y BSU)	77
18.3.7	D950 control	78
18.3.8	I2C Host interface	79
18.3.9	PCM and SPDIF	80

Table of Contents

18.3.10 I2S Data Input 0	81
18.3.11 I2S Data Input 1	82
19 ST18-AU1 PACKAGE SPECIFICATIONS	83
19.1 ST18-AU1 PACKAGE PINOUT	83
19.2 160 PIN PQFP PACKAGE DIMENSIONS	84
20 DEVICE ID	86
21 ORDERING INFORMATION	86

1 INTRODUCTION

The ST18-AU1 is a single-chip multi-function audio processor for Dolby AC-3, MPEG-1/MPEG-2 Layer-I/II audio encoded bitstreams, and DVD Linear PCM. It is capable of decoding up to 5.1 channels of input Dolby AC-3 or MPEG-2 multi-channel encoded audio, and down mixing to 2 channels of PCM output audio. Maximum input data rates for Dolby AC-3 bitstream and MPEG-2 audio bitstream are 448 Kbits/s and 912 Kbits/s respectively. It also supports up to 8 channel linear PCM input with by-pass, down-sampling, and down-mixing function. The linear PCM multi-channel input modes available are:

- 48 kHz/16-bit up to 8 ch @ max 6.144 Mbps
- 48 kHz/20-bit up to 6ch @ max 5.760 Mbps
- 48 kHz/24-bit up to 5ch @ max 5.760 Mbps
- 96 kHz/16-bit up to 4ch @ max 6.144 Mbps
- 96 kHz/20-bit up to 3ch @ max 5.760 Mbps
- 96 kHz/24-bit up to 2ch @ max 4.608 Mbps
- 44.1 kHz/16-bit 2ch (CD-DA).

The input bitstream is taken from the multi-format serial input, and decoded according to the selected MPEG-1, MPEG-2 (in the case of Karaoke capable mode), AC-3 decoder or Linear PCM processor. A Packet Demux de-multiplexes the input if it is MPEG-1 or DVD/MPEG-2 PES packetized. For an input bitstream with more than 2 encoded audio channels, the decoded channels are mixed down to 2 channels with the Dolby Surround compatible or karaoke capable option, and outputted through a multi-format serial output port. The input AC-3, MPEG bitstream, or decoded PCM can be outputted through an IEC-958 (S/PDIF) Formatter/Transmitter. The AC-3 or MPEG S/PDIF output bitstream is delayed and synchronized with the output decoded PCM.

The Karaoke Capable mode defined in Dolby AC-3 or DVD to allow the multi-channel audio stream to convey channels designed as L, R (2-ch stereo music), M (guide melody), and V1, V2 (one or two vocal/supplementary tracks) are supported. This Karaoke capable decoder allows the user to choose to have the decoder reproduce any of the guide melody and vocal/supplementary channels. Centre and surround mix levels either controlled by the user or within the bitstream are used to down mix the M channel and the V1, V2 channels respectively.

The selectable Linear PCM Processor functions are:

- down-mixing to 2 channels,
- down-sampling for 96kHz to 48kHz,
- noise shaped quantization for 24-bits or 20-bits to 16-bits.

Depending on the application, the decoded PCM audio output is selectable to be 16, 18, 20 or 24 bits, and the sampling rates of the PCM output are 32 kHz, 44.1 kHz, 48 kHz or 96 kHz.

External A/V synchronization can be assisted by the System Time Clock (STC) within the Timer and the PTS extracted from the packetized input. A serial I²C interface to host

ST18-AU1

microcontroller is provided to allow ST18-AU1 operation control, bitstream information and internal status access.

A typical DVD back-end system configuration is shown in Figure 1.1.

Figure 1.1 Typical DVD back-end system configuration

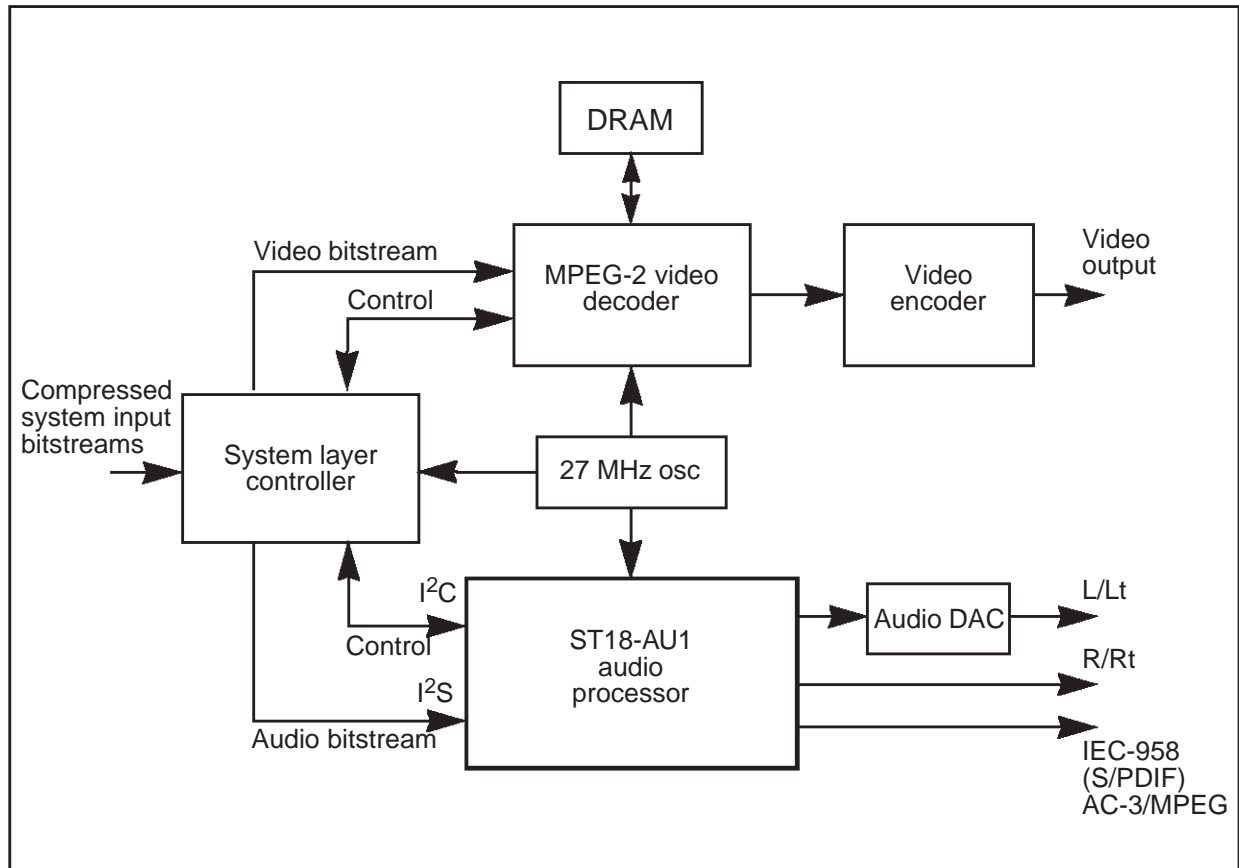

2 PIN DESCRIPTIONS

The following tables detail the ST18-AU1 pin set. There is one table for each group of pins. The tables detail the pin name, type and a short description of the pin function.

Signal names have a bar above if they are active low, otherwise they are active high.

Table 2.1 Direct I bus extension (35 pins)

Pin name	Type	Description
IDE0-15	I/O	Instruction data extension bus.
IAE0-15	O	Instruction address extension bus.
$\overline{\text{IRDE}}$	O	I-extension bus read strobe. Active low.
$\overline{\text{IWRE}}$	O	I-extension bus write strobe. Active low.
$\overline{\text{IBSE}}$	O	I-extension bus strobe. Active low. Asserted at the beginning of I-bus read/write cycle.

Table 2.2 Direct X bus extension / Bus extension through bus switch unit (39 pins)

Pin name	Type	Description
ED0-15	I/O	Bus switch unit (BSU) X/Y/I data extension bus.
EA0-15	O	BSU X/Y/I address extension bus.
$\overline{\text{EIRD}}$	O	BSU I-extension bus read strobe $\overline{\text{EIRD}}$ output.
$\overline{\text{EIWR}}$	O	BSU I-extension bus write strobe $\overline{\text{EIWR}}$ output.
$\overline{\text{XBSE}}$	O	X_extension bus data strobe (BSU not used).
$\overline{\text{EYRD}}$	O	BSU Y-extension bus read strobe $\overline{\text{EYRD}}$ output.
$\overline{\text{EYWR}}$	O	BSU Y-extension bus write strobe $\overline{\text{EYWR}}$ output.
$\overline{\text{XRDE_EXRD}}$	O	Multiplexed output. In direct X-bus extension mode (BSU not used): X-extension bus read strobe ($\overline{\text{XRDE}}$). Active low when reading from external X-memory. In X extension through BSU mode: BSU X-extension bus read strobe ($\overline{\text{EXRD}}$). Active low when reading from external memory (when bit I/M of XER register is '1': Intel mode). BSU extension bus data strobe ($\overline{\text{EDS}}$). Active low when reading from or writing to external memory (when bit I/M of XER register is '0' Motorola mode).
$\overline{\text{XWRE_EXWR}}$	O	Multiplexed output. In direct X-bus extension mode (BSU not used): X-extension bus write strobe ($\overline{\text{XWRE}}$). Active low when writing to external X-memory. In X extension through BSU mode: BSU X-extension bus write strobe ($\overline{\text{EXWR}}$). Active low when writing to external memory (when bit I/M of XER register is '1': Intel mode). Extension bus read /write signal ($\overline{\text{ERD_WR}}$). Low during write cycle, otherwise high (when bit I/M of XER register is '0': Motorola mode).

Table 2.3 General purpose parallel port (8 pins)

Pin name	Type	Description
P0-7	I/O	Parallel port I/O. Each pin can be programmed as input or output. On reset, all pins are inputs.

Table 2.4 Clocks (13 pins)

Pin name	Type	Description
EXTAL0	I	Oscillator0 input. DSP PLL.
XTAL0	O	Oscillator0 output. Nominal oscillator frequency is 27 MHz.
EXTAL1	I	Oscillator1 input. Audio PLL
XTAL1	O	Oscillator1 output. Nominal oscillator frequency is 27 MHz.
CLK0	I	Direct clock input for D950 core.
CLK0_MODE	I	Clock0 mode select input. When low, select output of DSP PLL for DSP Clock In When high, select CLK0 (bypass DSP PLL) for DSP Clock In
CLK1	I	Direct audio clock input.
CLK1_MODE	I	Clock1 mode select input. When low, select output of audio PLL for audio clock When high, select CLK1 (bypass audio PLL) for DSP Clock In
PLL_MODE	I	PLL mode select input When low, select oscillator 1 for audio PLL When high, select oscillator 0 for audio PLL
CLKOUT	O	Output clock (at input clock/2 frequency).
INCYCLE	O	Instruction cycle. Asserted high for 1 CLKOUT cycle at the beginning of instruction cycle.
SCLK	I/O	External audio clock/audio clock prescaler output
MCLK_MODE	I	SCLK mode select input When low, SCLK = output (internal audio master clock from clock prescaler) When high, SCLK = input (external audio master clock)

Table 2.5 I²C Host interface (3 pins)

Pin name	Type	Description
HDA	I/O	I ² C Data input/output (open drain output).
HCL	/O	I ² C Clock input/output (open drain output).
HSAS	I	Slave address select

Table 2.6 Data input 0 (4 pins)

Pin name	Type	Description
DIN0	I	Serial data input
CLKDIN0	I/O	Data input clock Input in slave mode, output in master mode.
WSDIN0	I/O	Data input word select Input in slave mode, output in master mode.
$\overline{\text{DREQ0}}$	O	Request for data input. Active low.

Table 2.7 Data input 1 (3 pins)

Pin name	Type	Description
DIN1	I	Serial data input
CLKDIN1	I	Data input clock Input in slave mode, output in master mode.
WSDIN1	O	Data input word select Input in slave mode, output in master mode.

Table 2.8 PCM output (5 pins)

Pin name	Type	Description
PCM_OUT0	O	PCM data output 0
PCM_OUT1	O	PCM data output 1
PCM_OUT2	O	PCM data output 2
SCLKPCM	O	PCM output clock (common)
WSPCM	O	PCM output word select (common)

Table 2.9 IEC-958 transmitter (SPDIF) output (1 pin)

Pin name	Type	Description
SPDIFOUT	O	S/PDIF signal

Table 2.10 Interrupt controller interface (1 pin)

Pin name	Type	Description
IRQ	I	Interrupt request. Active low. Maskable, programmable as falling edge or low level triggered (default is level triggered).

Table 2.11 D950-Core control (3 pins)

Pin name	Type	Description
$\overline{\text{RESET}}$	I	Reset input. Active low. Initializes the 950-Core to the Reset state.
$\overline{\text{LP}}$	I	Low power input. Active low.
MODE_RESET	I	Mode selection for Reset. When low, forces reset address to 0x0000. When high, forces reset address to 0xFC00.

Table 2.12 Emulation unit (4 pins)

Pin name	Type	Description
$\overline{\text{ERQ}}$	I	Emulator halt request. Active low. Halts program execution and enters emulation mode.
IDLE	O	Output flag asserted high when the processor is halted due to an emulation halt request or a valid breakpoint condition. Asserted low when the processor is not Halted or during execution of an instruction under control of the emulator.
HALTACK	O	Halt acknowledge. Active high. Asserted high when the processor is halted from an Emulator Halt request or when a valid Breakpoint condition is met.
SNAP	O	Snapshot. Active high. Asserted high when executing an instruction if Snapshot mode is enabled.

Table 2.13 JTAG IEEE 1149.1 test access port(5 pins)

Pin name	Type	Description
TDI	I	Test data input.
TCK	I	Test clock.
TMS	I	Test mode select.
TDO	O	Test data output.
$\overline{\text{TRST}}$	I	Test logic reset (also used for Emulator module). Active low.

3 FUNCTIONAL OVERVIEW

A functional block diagram of the ST18-AU1 is shown in Figure 3.1. The modules that comprise the ST18-AU1 are outlined below and more detailed information is given in the following chapters of this datasheet. The interconnection of these blocks and all external interfaces are shown in the block diagram in Figure 3.2.

Figure 3.1 Functional block diagram

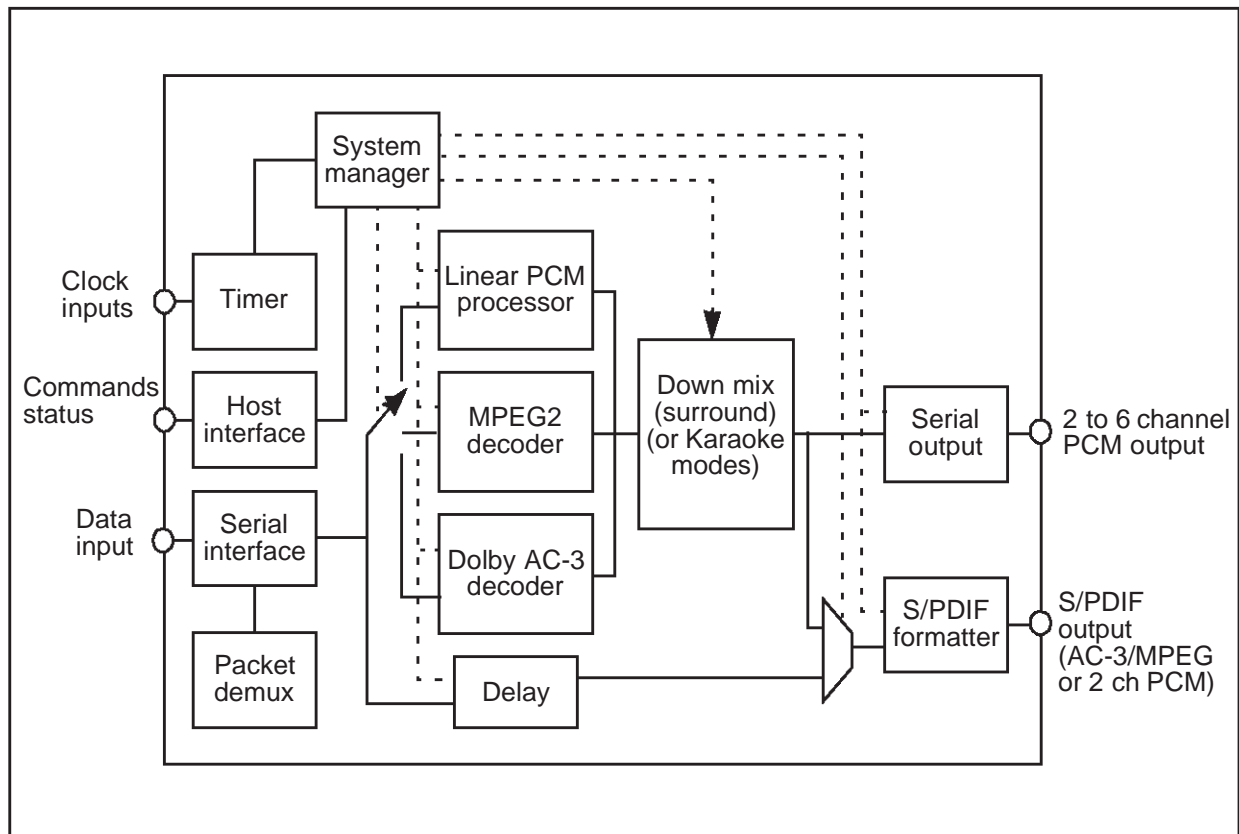
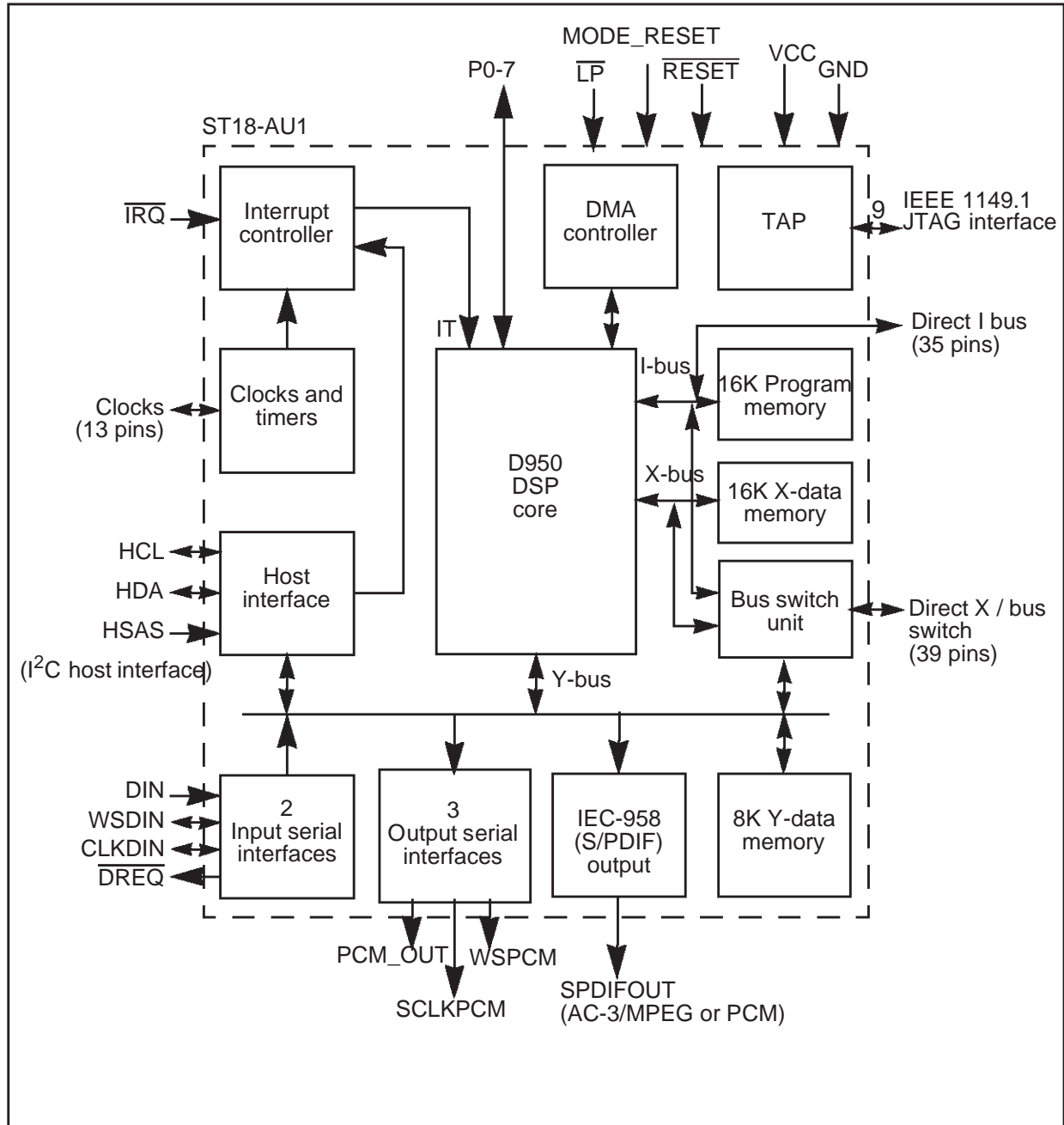

Figure 3.2 ST18-AU1 block diagram



Host interface

The I²C serial bus interface operated in slave mode enables connection to an external host processor. It receives operating commands, and returns host requested bitstream information and internal status.

ST18-AU1

Input serial interface

The ST18-AU1 has two input serial interfaces. The interfaces are multi-format serial interfaces for inputting audio bitstreams. Supported formats include delayed (I²S)/non-delayed, left/right justified, 16/18/20/24-bit word, polarity options in L/R clock and input clock, and master/slave mode. They provide the serial to parallel conversion and transfer the input data to the input buffer for further processing.

Output serial interface

The ST18-AU1 has three output serial interfaces. The output serial interfaces organize the PCM audio output into the required I²S serial format and generate all the DAC control signals.

IEC-958 transmitter

The IEC-958 transmitter accepts either the AC-3/MPEG bitstream or the decoded audio output PCM data, and formats the input in accordance with the IEC-958 (S/PDIF) specification for output.

Interrupt controller (ITC)

The interrupt controller (ITC) manages the interrupts from the clocks and timers unit, the host interface, and the external interrupt for the DSP core. The interrupt can be activated and programmed as edge or level triggered.

DMA controller (DMAC)

The DMA controller (DMAC) controls data transfer between data input/output and internal data buffers.

D950 DSP Core

The D950-Core is a general purpose programmable 16-bit fixed point Digital Signal Processor Core. The main blocks of the D950-Core include an arithmetic data calculation unit, a program control unit and an address calculation unit, able to manage up to 64k (program) and 128k (data) x 16-bit memory spaces.

The DSP core processes all host commands, performs input bitstream parsing, decompression, sample down-mixing and/or subsampling, as well as input and output control.

Memory

There is 8 Kword Y-data memory on Y space, 16 Kword X-data memory on X space and 16 Kword instruction memory on I space.

Memory can be extended off-chip in one of three ways:

- Direct I-bus extension.
- Direct X-bus extension.
- I, X and Y -bus extension through the bus switch unit.

Bus switch unit

The bus switch unit (BSU) is a bi-directional switcher. It switches the 3 internal buses (I, X and Y) to the external (E) bus.

Clocks and timers unit

The clocks and timers unit provides all the necessary clocks and timer controls for DSP processing, and all input/output operations. In addition, a 90 kHz System Time Clock (STC) is provided to assist audio/video synchronization in systems which include a video decoder.

Emulation unit and JTAG IEEE 1149.1 test access port

The emulation unit (EMU) performs functions dedicated to emulation and test through the external IEEE 1149.1 JTAG interface.

4 HOST INTERFACE

The host interface is a fast I²C serial bus interface operated in slave mode. It provides connection to an external host processor. It receives operating commands, and returns host requested bitstream information and internal status.

4.1 Host interface registers

HSER: Host serial shift register

This 16-bit shift register is used for serial data input and output. Data is shifted MSB first. It is not visible from the D950.

HDR: Host data register

This register is used for transfers between the HSER register and the D950.

Figure 4.1 Host interface data exchange, receive mode

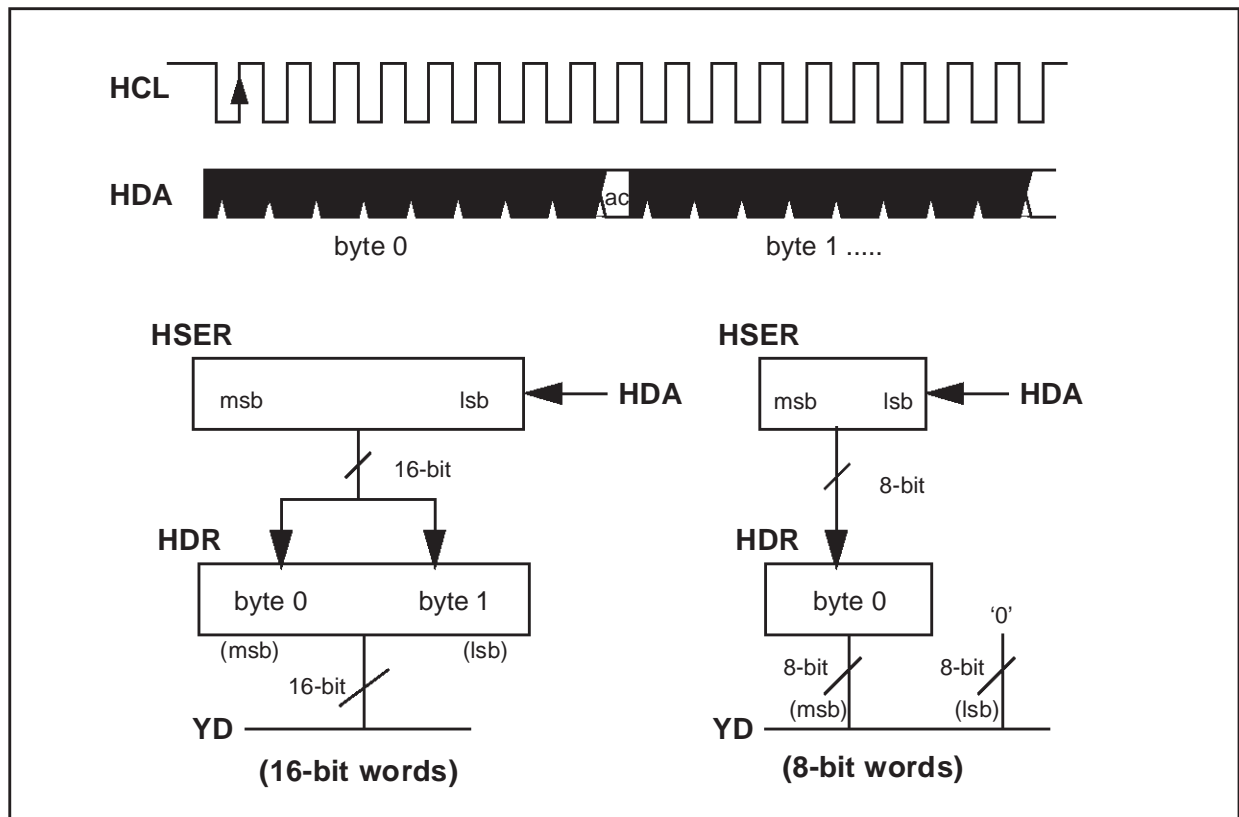
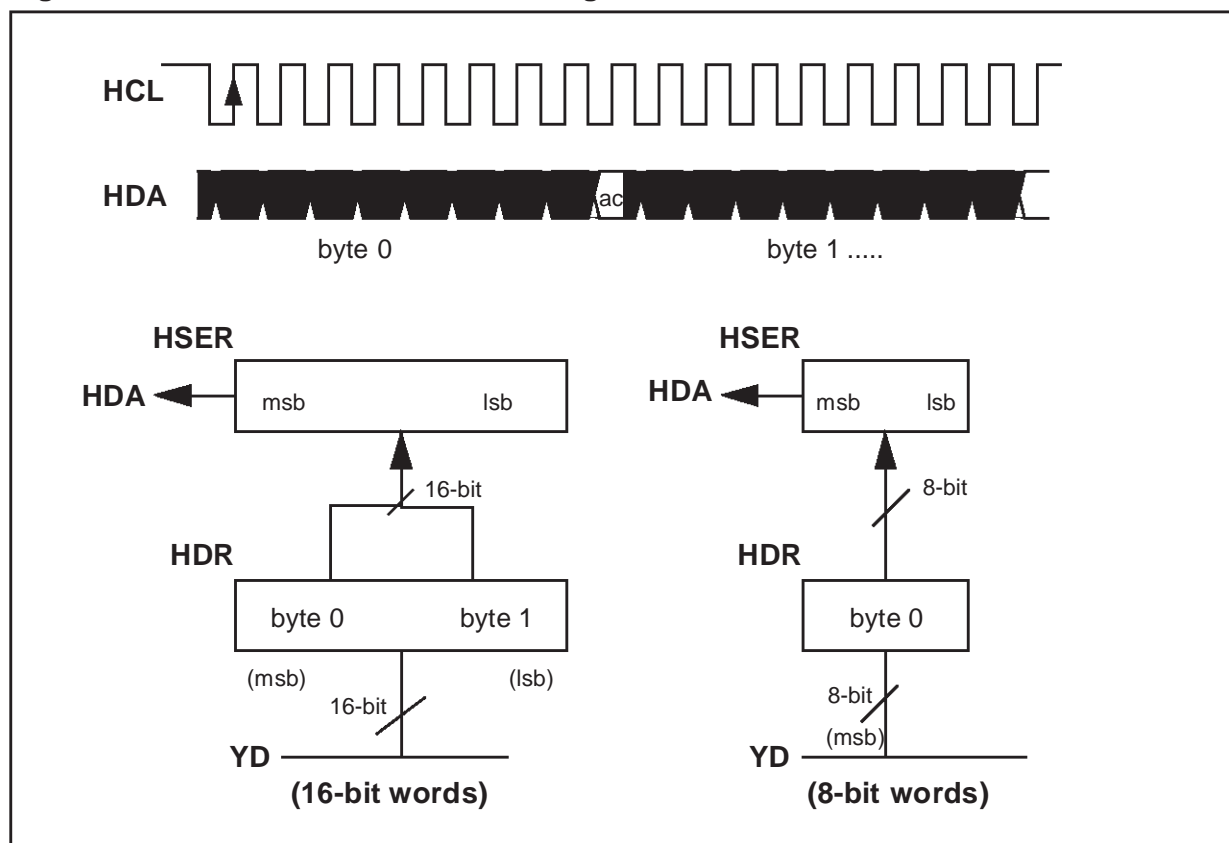

Figure 4.2 Host interface data exchange, send mode

**HCR: Host control register**

All bits are cleared on reset.

15	14	13	12	11	10	9	8	7	6	5	4	3	2	1	0
-	-	-	BER-RIEN	ACK-FIEN	STOPI-EN	-	HTIEN	-	-	-	-	-	ACK-OFF	WS	HEN

Bit	Function
HEN	Host interface enable 0 host interface disabled 1 host interface enabled
WS	Word size 0 8-bit word 1 16-bit word
ACKOFF	Acknowledge generation disable 0 acknowledge enabled 1 acknowledge disabled

ST18-AU1

HTIEN	Transfer interrupt enable 0 transfer interrupt disabled 1 transfer interrupt enabled
STOPIEN	Stop interrupt enable 0 stop interrupt disabled 1 stop interrupt enabled
ACKFIEN	Acknowledge fail interrupt 0 acknowledge fail interrupt disabled 1 acknowledge fail interrupt enabled
BERRIEN	Bus error interrupt 0 bus error interrupt disabled 1 bus error interrupt enabled
-	RESERVED, read as 0.

HSR: Host status register

All bits are reset when the register is read. The register can only be read by the D950.

15	14	13	12	11	10	9	8	7	6	5	4	3	2	1	0
-	-	-	BERR	ACK- FAIL	STOP	HDRR RQ	HDRW RQ	-	-	-	-	-	-	DAT- ADIR	BUSY

Bit	Function
BUSY	Set when Valid slave address detected, until Stop event or Restart event with invalid slave address.
DATADIR	Data direction (valid when Busy bit is set). 0 receive data from host 1' send data to host
HDRWRQ	HDR write request. Set when data is required by the host. Data needs to be written into the HDR register, this is reset when the HSR register is read.
HDRRRQ	Host read request. Set when data has been sent by the host. Data needs to be read from the HDR register, this is reset when the HSR register is read.
STOP	Stop. Set when a stop condition is detected.
ACKFAIL	Acknowledge fail. Set when the host does not generate an acknowledge after one data byte has been sent.
BERR	Bus error. Set when a misplaced start or stop condition is detected during transmission.
-	RESERVED, read as 0.

HSAR: Host slave address register

(Default value for slave address on reset: HSAS (7...2) = 101000).

15	14	13	12	11	10	9	8	7	6	5	4	3	2	1	0
HSA7	HSA6	HSA5	HSA4	HSA3	HSA2	HSA1	HSA0	-	-	-	-	-	-	-	-

Bit	Function
HSA0	Data direction (read only, written from HSER when Slave address is send by the host.)
HSA1	Slave address bit 1 (read only, value of pin HSAS)
HSA2	Slave address bit 2
HSA3	Slave address bit 3
HSA4	Slave address bit 4
HSA5	Slave address bit 5
HSA6	Slave address bit 6
HSA7	Slave address bit 7
-	RESERVED, read as 0.

4.2 List of host commands

A list of host commands is given below.

Table 4.1 Write commands

Mnemonic	Opcode	Size (bits)	Command description and Parameter values
HostInputMode	00	8	Input mode (type of bitstream). AC3 (default) 00 MPEG -1 01 MPEG-2 02 MPEG-2 with extension 03 PCM by pass 04 Linear PCM 05
HostInputStrmFormat	01	8	Input Stream Format ES (Default) 00 DVD/PES 01
HostOpmode	02	8	Operating Mode Idle (no decoding) (default) 00 Start (starts selected decoder) 01 Stop and flush (stops decoder and flush buffers) 02 Reset 03 SelfTest 04
HostMute	03	8	Mute Off (default) 00 On 01
HostAudiStrmIdSel	04	8	Audio stream ID select ID = 0 (default) to 7 (e.g. language selection) 00 - 07
HostOutputChanConf	05	8	Output channel configuration. 2/0 Lt/Rt, Dolby surround compatible X0 1/0 C X1 2/0 L/R (default) X2 3/0 LCR X3 2/1 LRI X4 3/1 LCRI X5 2/2 LRlr X6 3/2 LCRIr X7 Karaoke capable no vocal 0X Karaoke capable vocal 1 1X Karaoke capable vocal 2 2X Karaoke capable vocal 1 & 2 (default Karaoke) 3X where X = do not care
HostDualMonoReproMode	06	8	Dual mono reproduction mode Stereo (default) 00 Left mono 01 Right mono 02 Mixed mono 03

Table 4.1 Write commands

Mnemonic	Opcode	Size (bits)	Command description and Parameter values
HostDynRngeCompMode	07	8	Dynamic Range Compression Mode Line-out Mode 00 Custom Mode, Analog Dialnorm 01 Custom Mode, Digital Dialnorm (default) 02 RF Demod Mode 03
HostDynRngeCutScaleFac	08	16	Dynamic Range Compression Cut Scale Factor 0 to 0x7FFF (at '0' the compression is minimum, at 0x7fff the compression is maximum). (default: 0x 7fff)
HostDynRngeBstScaleFac	09	16	Dynamic Range Compression Boost Scale Factor 0 to 7FFF (at '0' the boost is minimum, at 0x7fff the boost is maximum). (default: 0x7fff)
HostPcmScaleFac	0A	16	PCM Scale Factor 0 to 7FFF (default)
HostOutLfeOn	0B	8	Output LFE Present Off (default) 00 On 01
HostSpdifOutStrmFormat	0C	8	SPDIF Output Stream Format (the SPDIF output can send either the PCM decoded output, or the input encoded elementary stream) AC3/MPEG (default) 00 PCM 01
HostSpdifOutputLatency	0D	16	SPDIF Output Latency Delay between the decoder and the bitstream sent via the SPDIF output. The delay is expressed in multiples of 1/Fs, where Fs is the sample frequency. The delay is signed. 0xffff to 0x7ffff (default: 0)
HostSpdifSmppteFrmRat-Cod	0E	16	SPDIF SMPTE Frame Rate Code not indicated 00 24/1001 01 24 02 25 03 30/1001 (default) 04 30 05 50 06 60/1001 07 60 08

Table 4.1 Write commands

Mnemonic	Opcode	Size (bits)	Command description and Parameter values
HostLpcmMixAlpha0-7 HostLpcmMixBeta0-7	0F-16 17-1E	16	Linear PCM Downmixing Coefficients In LPCM mode: Alpha _i is the coefficient to downmix the channel <i>i</i> into the Left channel. Beta _i is the downmixing coefficient for channel <i>i</i> into the Right channel. In Ac-3 Karaoke mode: the Alpha0 to Alpha5 are used to downmix respectively the Left, Melody, Right, Vocal1, Vocal2 channels. Beta0 to Beta5 is respectively used to downmix into the Right channel. Alpha0 to Alpha7, Beta0 to Beta7.
HostErrorConcealMod	1F	8	Error Concealment Mode Mute (default) 00 Disabled 01 Skip 02
HostLowPower	20	8	Low Power Stand-by Mode Off (default) 00 On 01
HostSerialInputCtrl	21		Serial Input Control Defines the input format. default: I2S slave
HostSerialInoutDiv	22		Serial Input Clock Division In master mode define the clock rate of the input.)
HostSerialOutputCtrl	23		Serial Output Control Defines the output format. default: I2s master
HostSerialOutputDiv	24	16	Serial Output Clock Division In master mode define the clock rate of the output. default: set for 44.1 Hz
HostAudioClockSel	25		Audio Clock Selection All clocks derived from the 27MHz (default) 11
HostSamplFreq	26	16	Audio Sample Frequency (Hz) 3200 10 44100 (default) 00 48000 01
HostPcmNbBits	27	16	Number of bits per sample 16 (default) 16 18 18 20 20
WriteStc	80	32	System Time Clock

Table 4.2 Read commands

Mnemonic	Opcode	Size (bits)	Command description and parameter value
HostVersion	40	16	Version number
HostI2cStatus	41	8	I2cStatus No error 00 Error 01
HostInputStatus	42	8	InputStatus No error 00 Overflow 01 Underflow 02
HostOutputStatus	43	8	OutputStatus No error 00 Underflow 01 Overflow 02 Error decoder 04
HostSPDIFStatus	44	8	SPDIF Status No error 00 Error 01
HostOpMode	45	8	OutputMode (Refer to output channel configuration)
HostAudDecodErrorStatus	46	16	Audio Decoder Error Status No error 0 Sync word 1 Sample frequency 2 Frame size 3 Number of channels 4 Decoder errors 5...f Crc 10
HostInputSamplFreq	47	8	Input Sampling Frequency Sampling frequency specified by the bitstream. For AC-3 fscod is returned.
HostInputDatRate	48	8	Input Data Rate Data rate specified by the bitstream. For AC-3 frmsizecod is returned.
HostInputMultiChanMode	49	8	InputMultiChannelMode For AC-3 acmod is returned.
HostKaraokeCapBitstrm	4A	8	Karaoke Bitstream Non Karaoke 00 Karaoke 01

Table 4.2 Read commands

Mnemonic	Opcode	Size (bits)	Command description and parameter value
HostLfePresent	4B	8	Lfe Present Lfe not present 00 Lfe present 01
HodtCopyProtect	4C	8	Copy Protected Not protected 00 Protected 01
HostOpModeOut	4D	8	Operating Mode Idle 00 Synchronising 01 Decoding 02
HostInputBitstrmStatus	4E	8	Input Bitstream Status Idle 00 Searching for PES sync word 01 Searching for audio frame sync word 04
STC	81	32	System Time Clock
PTS	82	32	Presentation Time Stamp

5 INPUT SERIAL INTERFACE

The ST18-AU1 has two input serial interfaces (DIN0 and DIN1). The interfaces are multi-format serial interfaces for inputting audio bitstreams. Supported formats include delayed (I²S)/non-delayed, left/right justified, 16/18/20/24-bit word, polarity options in L/R clock and input clock, and master/slave mode. They provide the serial to parallel conversion and transfer the input data to the input buffer for further processing.

Data input interface 0 (DIN0) operates with an input FIFO which regulates the input data flow transferred to the input buffer. Data input interface 1 (DIN1) operates in a similar way to DIN0 but it does not have an associated input FIFO.

5.1 Input serial interface registers

Each input serial interface has the following set of registers.

DIN0-1CR: Data in control register

On reset, all bits are cleared.

15	14	13	12	11	10	9	8	7	6	5	4	3	2	1	0
-	-	-	-	-	-	-	-	Master	Justified	Delayed	WS_pol	CLK_pol	WS		DIN-EN

Bit	Function
DINEN	Input interface enable 0 input interface disabled 1' input interface enabled
WS	Input word size Bit1 Bit 0 Input word size 0 0 16 bit 0 1 18 bit 1 0 20 bit 1 1 24 bit
CLK_pol	Clock polarity 0 data and WS change on Clk falling edge 1 data and WS change on Clk rising edge
WS_pol	Word size polarity 0 Left data word = WS low, Right data word = WS high 1 Left data word = WS high, Right data word = WS low
Delayed	Delay inserted before first bit of data following transition of WS. 0 first bit of data occurs on transition of WS 1 first bit of data occurs with 1 Clk cycle delay relative to transition of WS (I ² S compatible).

ST18-AU1

Justified	<p>If number of Clk cycles between WS transitions is $> n$ (= word size)</p> <p>0 start justified: n bits read, starting from first bit: just after WS transition if Delayed = '0' with 1 clk cycle delay after WS transition if Delayed = '1'</p> <p>1 end justified, end bit been last bit received: just before WS transition if Delayed = '0' just after WS transition if Delayed = '1'</p>
Master	<p>Master or slave operation</p> <p>0 slave 1 master</p> <p>NOTE: this bit must be defined before the input interface enable (DINEN) bit is set.</p>
-	RESERVED, read as 0.

DIN0-1DIV: Data in division register

On reset, DIN0DIV value is set to 0.

15	14	13	12	11	10	9	8	7	6	5	4	3	2	1	0			
-	-	-	-	-	-	-	-	DINDIV										

Bit	Function
DINDIV	<p>MCLK_DIN divide factor</p> <p>00000000' 1 00000001 2 11111111 '510 '</p> <p>$f_{CLKDIN} = f_{MCLK_DIN} / 2(DIN0DIV)$ if $DIN0DIV \neq '00000$</p>
	RESERVED, read as 0.

DIN1DR: Data in output register

This 16-bit register contains the serial interface input data and is read by the D950.

5.2 Input FIFO

Associated with input serial interface 0 (DIN0) is a 32 byte input FIFO. It is used for temporary storage of incoming data during processing of packet headers or AC3/MPEG decoding. The input FIFO provides the following:

- transfer of data to the input buffer on a word basis
- packet header processing when operating on PES
- detection of FIFO overflow and FIFO filled to a predefined level

5.2.1 Input FIFO registers

FIFO CR: Input FIFO control register

On reset, all bits are cleared. The FIFO is cleared and the formatter is set to the 'empty' state.

15	14	13	12	11	10	9	8	7	6	5	4	3	2	1	0
-	-	-	CLR_Form	-	DIN0_IEN	-	DREQ_SEL	FIFO_level					DMA_mod	DREQ_EN	-

Bit	Function
DREQ_EN	$\overline{\text{DREQ}}$ enable 0 $\overline{\text{DREQ}}=0$ 1 $\overline{\text{DREQ}}$ set according to FIFO threshold/full level
DMA_mod	DMA mode 0 DMA request always enabled 1 DMA request enabled only when PDC not equal to 0 (PES processing)
FIFO_level	FIFO threshold level (MSB=7, LSB=3). Set FIFO filling level for IRQ/DREQ management.
DREQ_SEL	$\overline{\text{DREQ}}$ signal settings (if DREQ_EN = 1) 0 $\overline{\text{DREQ}}$ is asserted high when FIFO threshold is reached 1 $\overline{\text{DREQ}}$ is asserted high when FIFO is full (if DREQ_EN=1)
DIN0_IEN	DIN0 interrupt enable 0 interrupt disabled 1' interrupt enabled (when FIFO_THS = 1)
CLR_Form	Set formatter empty (active only at write time of FIFO CR)
-	RESERVED, read as 0.

FIFOSR: Input FIFO status register

FIFO_FULL and FIFO_THR are cleared on reset.

15	14	13	12	11	10	9	8	7	6	5	4	3	2	1	0
-	-	-	Form_e mpty	PDC_N ULL	FIFO_T HR	FIFO_ EMPTY	FIFO_F ULL	-	-	-	-	-	-	-	-

Bit	Function
FIFO_FULL	FIFO full: set and reset by hardware
FIFO_EMPTY	FIFO empty: set and reset by hardware
FIFO_THR	FIFO threshold: set and reset by hardware
PDC_NULL	Set when PDC = 0, otherwise reset
Form_empty	Set when formatter empty, otherwise reset
-	RESERVED, read as 0.

FIFO_out: FIFO output data register

15	14	13	12	11	10	9	8	7	6	5	4	3	2	1	0
Data								-	-	-	-	-	-	-	-

Bit	Function
Data	Data (MSB=15, LSB=8)
-	RESERVED, read as 0.

FORM_out: Formatter output data register

15	14	13	12	11	10	9	8	7	6	5	4	3	2	1	0
DataH								DataL							

Bit	Function
Data L	Data least significant byte
Data H	Data most significant byte

PDCR: Packet data count register

Cleared on reset.

15	14	13	12	11	10	9	8	7	6	5	4	3	2	1	0
-	-	-	-	-	PDC										

Bit	Function
PDC	Packet data count value in bytes. Maximum count value is 2047.
-	RESERVED, read as 0.

6 INPUT AND OUTPUT BUFFERS

6.1 Input buffer

The input buffer is single port memory mapped on the Y space. Taking into account the requirements for AC3 decoding and SPDIF transmitter, its size is 2048 words (16-bit). It is software defined and may be dynamically sized. Buffer overflow detection is provided.

The D950 reads the buffer using its circular addressing mode of operation.

The DMA controller cycles through the buffer for write word by word, using a cycle stealing mechanism: 3 D950 cycles are needed for each 16-bit word transfer.

When the SPDIF transmitter is enabled, another DMA channel is assigned to retrieving encoded samples.

6.2 Output buffer

The output buffer is single port memory mapped on the X space.

For 2 channel and 6 channel PCM output, the size of the output buffer is software defined and can be dynamically sized.

The D950 cycles through the buffer for write by using its circular addressing mode of operation.

The DMA controller cycles through the buffer for read of one sample at a time (2 or 3 words, depending on samples format), using a cycle stealing mechanism.

In 2 channel output mode, one DMA channel is used.

In 6 channel output mode, three DMA channels are used.

The DMA channel used must operate on "Level" mode.

Buffer underflow detection can be performed using on-chip dedicated resources.

6.2.1 Input and output buffer registers

BUFCR: Buffer control register

All bits are cleared on reset.

15	14	13	12	11	10	9	8	7	6	5	4	3	2	1	0
-	-	-	-	-	-	UDF_OUT BUF_IEN	OVF_INB UF_IEN	-	-	-	-	-	UDF_ mod	OVF_IN BUF	EN_B UF

Bit	Function
EN_BUF	Enable input/output buffer logic
OVF_INBUF	Input buffer overflow 0 INBUFOVF= '0' 1 INBUFOVF=INBUF_FULL

ST18-AU1

UDF_mod	Output buffer underflow 0 OUTBUFUDF= '0' 1 OUTUFUDF=OUTBUF_EMPTY
OVF_INBUF_IEN	Input buffer overflow interrupt enable 0 disable 1 enable
UDF_OUTBUF_IEN	Output buffer underflow interrupt enable 0 disable 1 enable
-	RESERVED, Read as 0.

BUFSR: Buffer status register

All bits are cleared on reset.

15	14	13	12	11	10	9	8	7	6	5	4	3	2	1	0
-	-	-	-	-	-	OUTBUF_EMPTY	INBUF_FULL	-	-	-	-	-	-	-	-

Bit	Function
INBUF_FULL	Input buffer full. Set and reset by hardware.
OUTBUF_EMPTY	Output buffer empty. Set and reset by hardware.
-	RESERVED, Read as 0.

INBUFRAR: Input buffer read address register

This register is not initialized on Reset.

15	14	13	12	11	10	9	8	7	6	5	4	3	2	1	0
RADD															

Bit	Function
RADD	Reference address for Compare

OUTBUFWAR: Output buffer write address register

This register is not initialized on reset.

15	14	13	12	11	10	9	8	7	6	5	4	3	2	1	0
WADD															

Bit	Function
WADD	Reference address for Compare.

7 OUTPUT SERIAL INTERFACE - PCM OUTPUT

The output serial interface organizes the PCM audio output into the required I²S serial format and generates all the DAC control signals.

The PCM output interface can be programmed to meet various data formats and modes of operation. The following parameters can be configured: word size, clock polarity, WS polarity, delayed/non-delayed, start/end justified. They are defined by the content of the control register **PCMCR** and are described below.

7.1 Output serial interface registers

PCM_{PR}x0-x2 (x = 0, 1, 2): Data in parallel registers

The 9 PCM_{PR} registers are 16-bit PCM parallel registers used for temporary storage of output data.

- For 16-bit format, only the PCM_{PR}x0 and PCM_{PR}x1 registers are used respectively for channel 2 (right) and channel 1 (left).
- For formats of greater than 16-bits, the PCM_{PR}x2 registers are used for the LSB:
 - channel 2 LSB on bits 7 to 0, left justified.
 - channel 1 LSB on bits 15 to 8, left justified.

Figure 7.1 PCM_{PR} register example for 18-bit data words

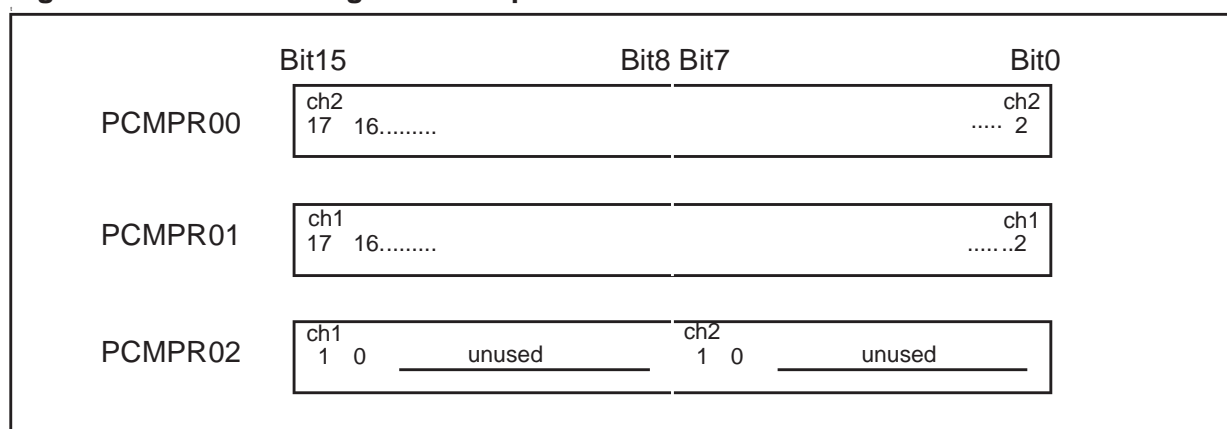

ST18-AU1

PCMCR: Data in control register

All bits are cleared on reset.

15	14	13	12	11	10	9	8	7	6	5	4	3	2	1	0
-	-	-	Mute _en	play	mute	PCM _ord	Mode	-	Justi- fied	De- layed	WS_p ol	CLK_ pol	WS		PC- MEN

Bit	Function
PCMEN	PCM output enable 0 disable 1 enable
WS	Output word size bit 1 bit 0 word size 0 0 16 bit 0 1 18 bit 1 0 20 bit 1 1 24 bit
CLK_pol	Clock pol 0 data and WS change on SCLKPCM falling edge 1 data and WS change on SCLKPCM rising edge
WS_pol	Word size pol 0 Left data word = WS low, Right data word = WS high 1 Left data word = WS high, Right data word = WS low
Delayed	Delayed 0 first bit of data occurs on transition of WS 1 first bit of data occurs with 1 SCLKPCM cycle delay relative to transition of WS. (I ² S compatible). Note: valid only for start justified mode, see bit 6.
Justified	If number of SCLKPCM cycles between WS transitions is > N (=Word size) 0 start justified: N bits read, starting from first bit: just after WS transition if Delayed = '0' with 1 clk cycle delay after WS transition if Delayed = '1' 1 end justified, end bit in last bit received: just before WS transition if Delayed = '0' just after WS transition if Delayed = '1'
Mode	Mode 0 2 channels 1 6 channels
PCM_ord	In 16-bit word-size, 0 MSB sent first 1 LSB sent first

mute	Play	Mute		
	0	0	no DMA req. serial out = 0 SCLK, WS not running	
	play	0	1	no DMA req. serial out = 0 SCLK, WS running
		1	0	DMA req. serial out = 'data' SCLK, WS running
	1	1	DMA req. serial out = 0 SCLK, WS running	
Mute_en	Mute enable			
	0	disable mute input		
	1	enable mute input		
	Bit mute is set by detection of falling edge on mute input It is cleared by writing '0' to it.			
-	RESERVED, read as 0.			

PCMDIV

On reset, the PCMDIV value is set to 0.

If the SPDIF transmitter is used:

- If output word size is greater than 16-bit, PCMDIV must be set to at least 1 (divide by 2) for correct generation of SPDIFCLK at twice the frequency of SCLKPCM.
- If output word size is 16-bit, PCMDIV must be set to at least 2 (divide by 4).

15	14	13	12	11	10	9	8	7	6	5	4	3	2	1	0
-	-	-	-	-	-	-	-	PCMDIV							

Bit	Function
PCMDIV	PCMCLK divide factor
	00000000 1
	00000001 2
	...
	11111111 510
	$f_{PCMCLK} = f_{MCLK_PCM} / 2(PCMDIV)$ if PCMDIV \neq '00000
-	RESERVED, read as 0.

8 INTERRUPT CONTROLLER

The interrupt controller (ITC) manages the interrupts from the clocks and timers unit, the host interface, and the external interrupt for the DSP core. The interrupt controller also manages input/output buffer overflow/underflow interrupts.

The interrupt controller has the following features:

- 8 interrupt sources
- interrupts can be individually enabled by software
- priority level between different sources can be set by software
- interrupt can be activated and programmed as edge or level triggered.

The interrupt controller $\overline{\text{ITRQ}}$ inputs are connected to one external interrupt request ($\overline{\text{IRQ}}$ pin) and to internal peripheral requests, as detailed in the table below.

Table 8.1 Interrupt assignments

Interrupt	Assignment
$\overline{\text{ITRQ0}}$	Host interface
$\overline{\text{ITRQ1}}$	Input FIFO
$\overline{\text{ITRQ2}}$	Input buffer
$\overline{\text{ITRQ3}}$	Output buffer
$\overline{\text{ITRQ4}}$	Clock timer IRQ
$\overline{\text{ITRQ5}}$	SPDIF timer IRQ
$\overline{\text{ITRQ6}}$	DMA controller
$\overline{\text{ITRQ7}}$	connected to the external $\overline{\text{IRQ}}$ pin

Figure 8.1 D950Core interrupt controller

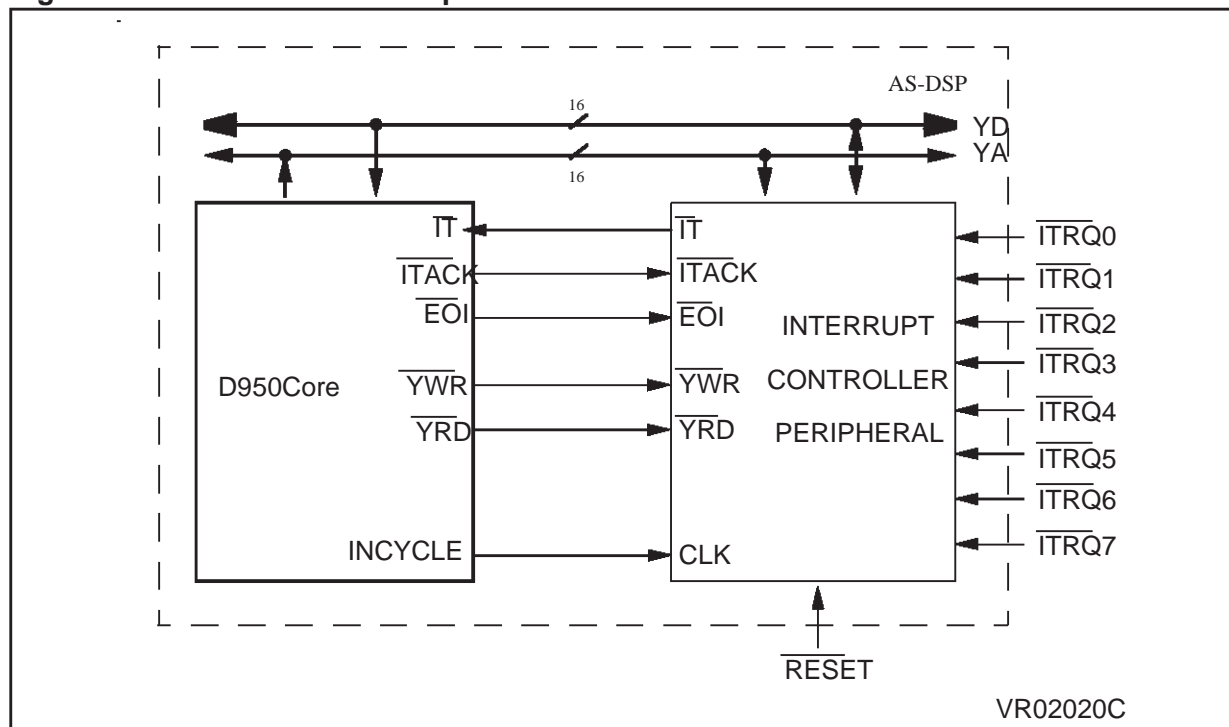

8.1 Interrupt controller registers

The interrupt controller interface is controlled by status and control registers mapped into the Y-memory space. Status registers are not write-protected.

IVO0-7: Interrupt vector0-7 address registers

The IVO0-7 registers contain the first address of the interrupt routine and are associated with the respective interrupt input \overline{ITRQ} , see Table 8.1. The register content of the interrupt under service is provided on the YD bus during the cycle following the \overline{ITACK} falling edge.

(Address = 0020-0027, No reset value, Read/Write)

15	14	13	12	11	10	9	8	7	6	5	4	3	2	1	0
IVi15	IVi14	IVi13	IVi12	IVi11	IVi10	IVi9	IVi8	IVi7	IVi6	IVi5	IVi4	IVi3	IVi2	IVi1	IVi0

ICR: Interrupt control register

The ICR register displays the current priority level and up to four stacked priority levels.

(Address = 0028, Reset = 000Bh, Read/Write))

15	14	13	12	11	10	9	8	7	6	5	4	3	2	1	0
SPL4 (2:0)			SPL3 (2:0)			SPL2 (2:0)			SPL1 (2:0)			ES	CPL (2:0)		

ST18-AU1

Bit	Function
CPL	Current priority level (-1, 0, 1, 2 or 3) (default is 011)
ES	Empty stack flag 0: stack is used 1: stack is not used (default)
SPL1	3-bit 1st stacked priority level
SPL2	3-bit 2nd stacked priority level
SPL3	3-bit 3rd stacked priority level
SPL4	3-bit 4th stacked priority level

The current priority levels available are shown below.

Priority level	Coding	Acceptable IT level priority
- 1	111	0,1,2,3
0	000	1,2,3
1	001	2,3
2	010	3
3	011	
Reserved	100 - 110	

One interrupt request is acknowledged whenever its priority level (coded in the IPR register) is higher than the current priority level. In this case, the current priority level becomes the interrupt priority level and the previous current priority level is pushed onto the stack and displayed as stack priority level (SPL)1.

The process is repeated over a range of four interrupt requests and the four previous current stack priority levels are displayed on SPL1, SPL2, SPL3 and SPL4. If less than four interrupts are pushed onto the stack, the unused SPL words are set to '000'. At the end of the interrupt routine, the priority levels are popped from the stack.

The empty stack (ES) flag is used to indicate whether the stack is used or not. The ISP word of the ISP register indicates the depth of the stack (see below).

Figure 8.2 ICR and ISPR Operation

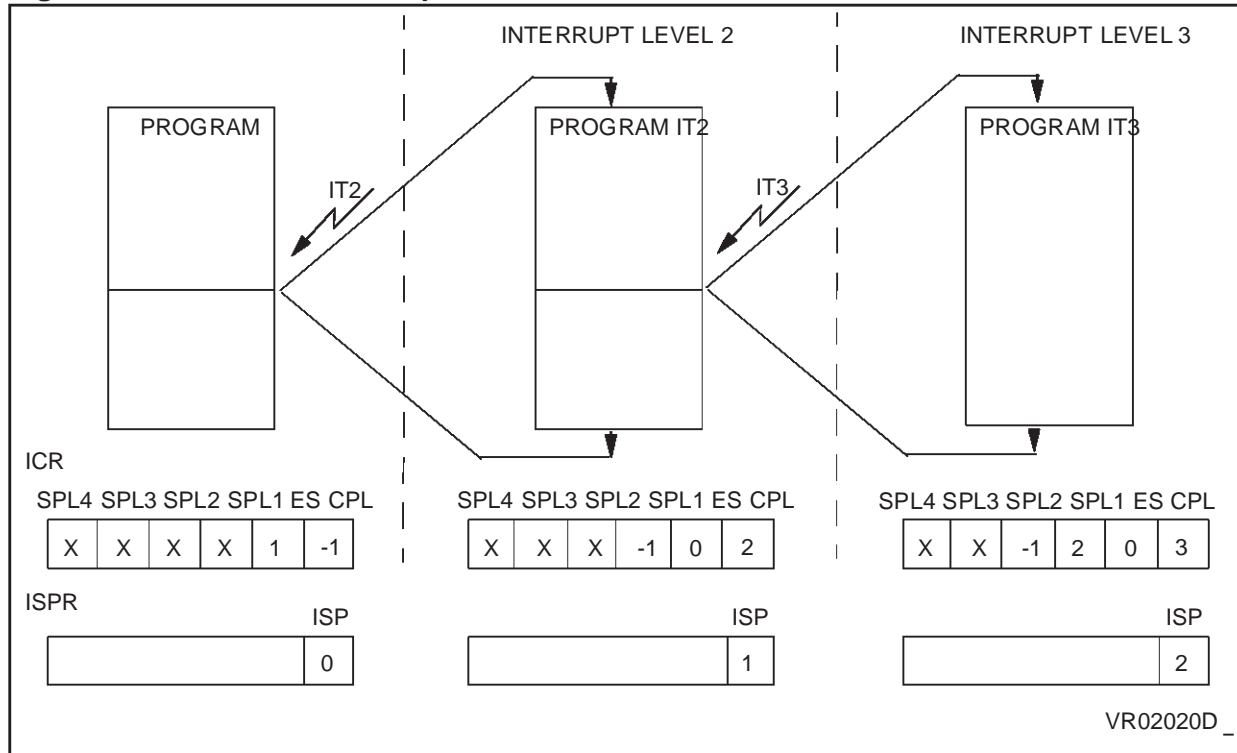

IMR: Interrupt mask/sensitivity register

(Address = 0029, Reset = 5555h, Read/Write))

15	14	13	12	11	10	9	8	7	6	5	4	3	2	1	0
IS7	IM7	IS6	IM6	IS5	IM5	IS4	IM4	IS3	IM3	IS2	IM2	IS1	IM1	IS0	IM0

Bit	Function
IM	Interrupt mask 0: Interrupt is not masked 1: Interrupt is masked (default)
IS	Sensitivity 0: \overline{ITRQ} is active on a low level (default) 1: \overline{ITRQ} is active on a falling edge

Each interrupt input $\overline{ITRQ0-7}$ can be masked individually when the corresponding IM0-7 bit is set. In this case any activity on the $\overline{ITRQ0-7}$ pin is ignored. All IM bits are set during DSP reset.

$\overline{ITRQ0-7}$ is active either on a low level when IS0-7 is low (by default on reset) or on a falling edge when IS0-7 is high.

When $\overline{ITRQ0-7}$ is active on a low level, it must stay low until the \overline{ITACK} falling edge is sampled.

Note, edge sensitive mode of operation must be set for all internal interrupt sources.

ST18-AU1

IPR: Interrupt priority register

(Address = 002A, Reset = 0000h, Read/Write)

15	14	13	12	11	10	9	8	7	6	5	4	3	2	1	0
IP7(1:0)		IP6(1:0)		IP5(1:0)		IP4(1:0)		IP3(1:0)		IP2(1:0)		IP1(1:0)		IP0(1:0)	

Bit	Function
IP	Interrupt priority level (0, 1, 2 or 3) (default is 0)

The IPR register contains the priority level of each $\overline{\text{ITRQ0-7}}$ interrupt input. IP0-7 priority level is coded using two bits. The different values of IP are 0, 1, 2, 3 (0 lowest priority, 3 highest priority).

When two $\overline{\text{ITRQ}}$ with the same priority level are requesting during the same cycle, the first acknowledged interrupt is the one corresponding to the lowest number (for example, $\overline{\text{ITRQ0}}$ acknowledged prior to $\overline{\text{ITRQ3}}$).

ISPR: Interrupt stack pointer register

(Address = 002B, Reset = 0000h, Read/Write)

15	14	13	12	11	10	9	8	7	6	5	4	3	2	1	0
-	-	-	-	-	-	-	-	-	-	-	-	-	ISP(2:0)		

Bit	Function
ISPR	Number of stacked priority levels (0, 1, 2 or 3)

Note: '-' is RESERVED (read: 0, write: don't care)

ISPR contains the number of stacked priority levels. If the ISPR value is directly written, the SPLi/CPL values are modified. So the ICR register content is no longer significant but the interrupt routine procedure is not affected. After reset, ISPR default value is 0

ISR: Interrupt status register

(Address = 002C, Reset = 0000h, Read/Write)

15	14	13	12	11	10	9	8	7	6	5	4	3	2	1	0
-	-	-	-	-	-	-	-	IPE7	IPE6	IPE5	IPE4	IPE3	IPE2	IPE1	IPE0

Bit	Function
IPE	Interrupt pending bit 0: Reset when interrupt request is acknowledged (default) 1: Set when interrupt request is recorded

Note: '-' is RESERVED (read: 0, write: don't care)

An interrupt pending (IPE) bit is associated with each interrupt input. IPE is set when the interrupt request is recorded and is reset when the interrupt request is acknowledged ($\overline{\text{ITACK}}$ falling edge).

When the user does not want to acknowledge any of the pending interrupt requests, the IPE flag of the CCR register must first be reset and then the ISR register set to "0000".

When only some pending interrupt requests need to be acknowledged, the IPE bits of the other interrupt inputs must be reset.

When the IPE bit is set by a direct register write an interrupt request will be generated irrespective of the state of the $\overline{\text{ITRQ}}$ pin.

When the mask (IM) bit is set, the corresponding IPE bit is reset.

9 DMA CONTROLLER

The DMA controller manages data transfer between memories and external peripherals and has the following features:

- four independent DMA channels
- transfers on X / Y / I spaces (simultaneous transfers on X and Y spaces)
- cycle stealing operation:
 - 3 cycles for a single data transfer (+1 cycle for transfers on I space)
 - (n+2) cycles for an n-data block transfer (+1 cycle for transfers on I space)
- each channel has:
 - 1 signal: interrupt request (\overline{ITR})
 - 4x16 bit registers for block transfer facilities
- fixed priority between the four channels (highest for channel 0, lowest for channel 3)

9.1 DMA operation

The four channels of D950 DMAC are used for:

- DMA3: transfer data from input FIFO to input buffer (Y space).
As single words are transferred, it must be programmed edge sensitive.
- transfer data from output buffer to PCM output (X space).
 - DMA0 in 2-channel output mode
 - DMA0, DMA1 and DMA2 in 6-channel output modethey must be programmed level sensitive.
- DMA1: transfer data from input buffer or output buffer to SPDIF interface.
This channel will be programmed for transfer with X or Y memory according to the mode of operation of the SPDIF transmitter. It must be programmed level sensitive.
(not compatible with 6-channel output mode.)
- DMA2: transfer data from DATA Input1 to Y memory.
As single words are transferred, it must be programmed edge sensitive.
(not compatible with 6-channel output mode.)

9.2 DMA registers

9.2.1 Address registers

Two 16-bit registers (unsigned) are dedicated per channel for transfer address:

- DIA0-3: initial address. This register contains the initial address of the selected address bus (see DBC-bit of DGC register).
- DCA0-3: current address. This register contains the value to be transferred to the selected address bus (see DBC-bit of DGC register) during the next transfer. The different DCA values are:

Reset	DAI	DLA	DCC	DCA(n+1)
1	X	X	X	0
0	0	X	X	DCA(n)
0	1	0	X	DCA(n) + 1
0	1	1	=0	DCA(n) + 1
0	1	1	=1	DIA

Note: See DAIC register for DAI and DLA definitions.

9.2.2 Counting registers

Two 16-bit registers (unsigned) per channel are dedicated for transfer count.

For a transfer of an N data block, DIC and DCC registers have to be loaded with $N-1$.

When DCC content is 0 (valid transfer count), it is loaded with DIC content for the next transfer.

- DIC0-3: initial count. This register contains the total number of transfers of the entire block.
- DCC0-3: current count. This register contains the remaining number of transfers required to fill the entire block. It is decremented after each transfer. The DCC values are:

Reset	DCC	DCA(n+1)
1	X	0
0	=0	DCA(n) - 1
0	=1	DIC

9.2.3 Control registers

Three 16-bit control registers are dedicated to the DMA controller interface. These are the general control register, the address interrupt control register and the mask sensitivity control register. They are detailed below.

DGC: General control register

Three bits are dedicated for each DMA channel (bits 0 to 2 to channel 0, bits 4 to 6 to channel 1, bits 8 to 10 to channel 2, bits 12 to 14 to channel 3).

(Address = 0040, Reset = 0000h, Read/Write).

15	14	13	12	11	10	9	8	7	6	5	4	3	2	1	0
-	DRW 3	DBC 1	DBC 0	-	DRW 2	DBC 1	DBC 0	-	DRW 1	DBC 1	DBC 0	-	DRW 0	DBC 1	DBC 0

Bit	Function
DBC1/DBC0	Bus choice for data transfer 00: X-bus (default) 01: Y-bus 10: I-bus 11: reserved
DRWi	Data transfer direction 0: Write access (default) 1: Read access

DAIC: Address/interrupt control register

Four bits are dedicated for each DMA channel (bits 0 to 3 to channel 0, bits 4 to 7 to channel 1, bits 8 to 11 to channel 2, bits 12 to 15 to channel 3).

(Address = 0042, Reset = 0000h, Read/Write)

15	14	13	12	11	10	9	8	7	6	5	4	3	2	1	0
DAI3	DLA3	DIP3	DIE3	DAI2	DLA2	DIP2	DIE2	DAI1	DLA1	DIP1	DIE1	DAI0	DLA0	DIP0	DIE0

Bit	Function
DIEi	Enable interrupt 0: Interrupt request output associated to channel i is masked (default) 1: Interrupt request output associated to channel i is not masked
DIPi	Interrupt pending 0: No pending interrupt on channel i (default) 1: Pending interrupt on channel i (enabled if DIP_ENA input is high)

DLAi:	Load address 0: DCAi content incremented after each data transfer (default) 1: DCAi content loaded with DIA content if DCCi value is 0, or DCAi content incremented if DCCi value is not equal to 0
DAIi	Address increment 0: DCAi content unchanged (default) 1: DCAi content modified according to DLAi state

DMS: Mask sensitivity control register

Two bits are dedicated to each DMA channel (bits 0 and 1 to channel 0, bits 4 and 5 to channel 1, bits 8 and 9 to channel 2, bits 12 and 13 to channel 3).

(Address = 0041, Reset = x3333h, Read/Write)

15	14	13	12	11	10	9	8	7	6	5	4	3	2	1	0
-	-	DSE3	DMK3	-	-	DSE2	DMK2	-	-	DSE1	DMK1	-	-	DSE0	DMK0

Bit	Function
DMKi	DMA mask 0: DMA channel not masked 1: DMA channel masked (default)
DSEi	DMA sensitivity 0: Low level 1: Falling edge (default)

10 IEC-958 TRANSMITTER

The IEC-958 transmitter accepts either the AC-3/MPEG bitstream or the decoded audio output PCM data, and formats the input in accordance with the IEC-958 (S/PDIF) specification for output via the SPDIFOUT pin.

For further information refer to the IEC-958 interface specification.

10.1 IEC-958 transmitter registers

CHANSTA1: Channel status register 1

Bit	Bit of C	Function
0	0	0 Consumer mode, fixed
1	1	Digital data 0 audio data, muted or pcm 1 compressed audio data
2	2	Copyright indication 0 digital copy prohibited 1 digital copy permitted
3-5	3-5	000 (Reserved)
6-7	6-7	Mode 0 00 (Fixed)
8-14	8-14	Category code 1001100 for DVD (AC3/MPEG)
15	Genera- tion status	0 original/commercially pre-recorded 1 no indication/1st generation or higher

Note: write only register.

CHANSTA2: Channel status register 2

Bit	Bit of C	Function
0-7	16-23	00000000 (Fixed)
8-11	24-27	0100 Fs 48kHz 0000 Fs 44.1kHz 1100 Fs 32kHz
12-13	28-29	00 clock precision fixed
14-15	30-191	all 0, fixed

Note: write only register.

SPDIFCR: SPDIF Output control register

Bit	Name	Function
0	SPDIFen	Enable 0 disabled 1 enabled
1-2	WS	Word size bit 1 bit 0 word size 0 0 16 bit 0 1 18 bit 1 0 20 bit 1 1 24 bit
3	X/Y	Select X/Y for data read 0 Y (input buffer) 1 X (output buffer)
4	V	Validity bit 0 valid 1 defective
5-15		RESERVED, written as 0.

Note: write only register.

All bits of the SPDIFCR register are cleared on reset.

SPDIFPR0-2: 3x 16-bit SPDIF parallel registers

The SPDIFPR0-2 registers are 16 bit SPDIF parallel registers used for intermediate storage of data. They are write only registers.

11 MEMORY

11.1 Internal memory resource

One 8 Kword and two 16 Kword single port memories are included on-chip:

- Instruction memory on I space from address 0 to 16382 (16 K)
- X-Data memory on X space from address 0 to 16382 (16 K)
- Y-Data memory on Y space from address 256 to 8192

Note: the first 256 addresses of the Y space are reserved for the D950 memory-mapped registers and for on-chip memory mapped peripherals.

Memory can be extended off-chip in one of two ways:

- 1: directly for I and X memory spaces
- 2: through the bus switch unit for all three memory spaces

The specific details on the operation of the BSU are described separately in Chapter 12.

Figure 11.1 Memory mapping

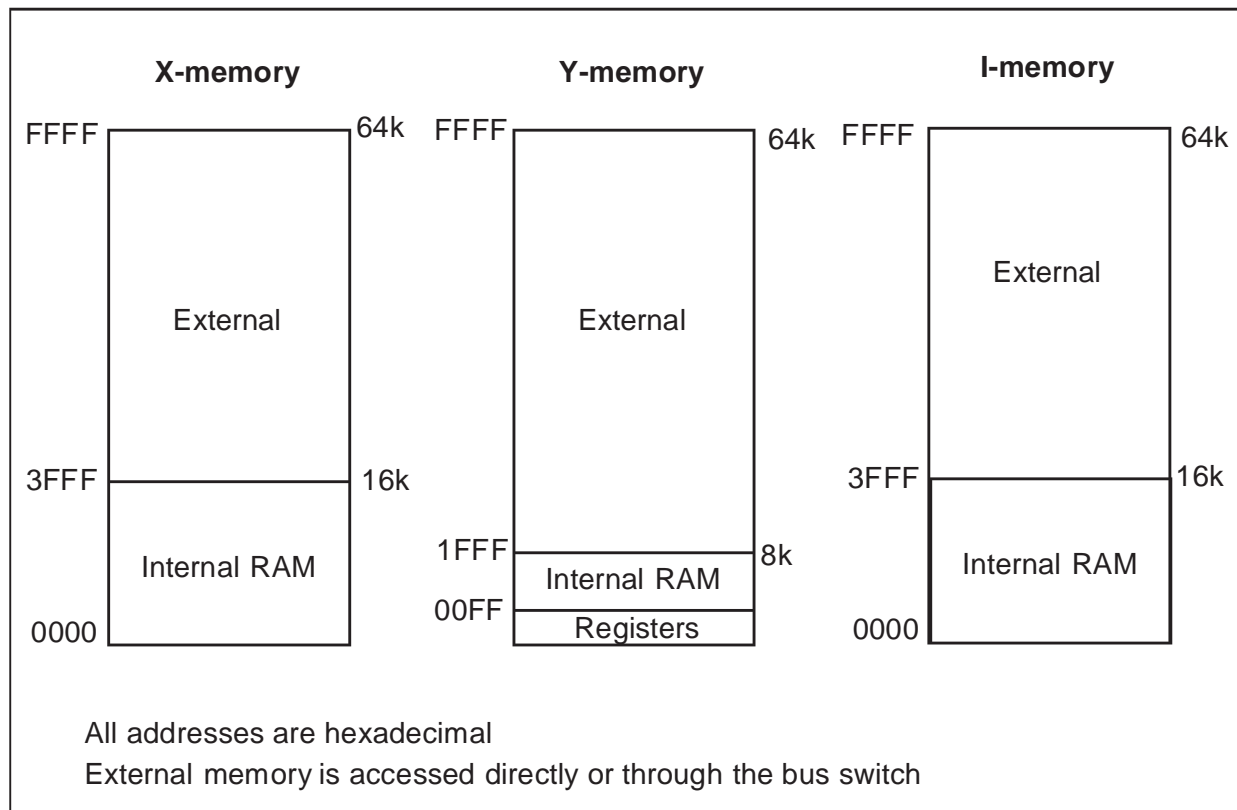

11.2 I-memory bus extension - direct and through BSU

For direct bus extension for I-memory the internal program memory is used from address 0 to 16383 (16K).

The BSU can be programmed to allow either direct extension or extension through the BSU for IA above 16383.

Note: Initial reset should occur with `MODE_RESET = 1`, because internal program RAM is not initialized.

11.3 X-memory bus extension - direct and through BSU

The internal program memory is used from address 0 to 16383 (16K).

Direct bus extension or bus extension through the BSU is controlled by setting the X-bus related BSU registers.

11.4 Y-memory bus extension through BSU

The internal program memory is used from address 256 to 8192.

Y-memory bus extension must be through the BSU. It is controlled by setting the Y-bus related BSU registers.

12 BUS SWITCH UNIT

The bus switch unit (BSU) is a bi-directional switcher. It switches the 3 internal buses (I, X and Y) to the external (E) bus.

12.1 BSU control registers

The BSU is programmable via six control registers mapped in the Y-memory space. These define the type of memory used, internal to external boundary address crossing, exchange type (external direct or through the BSU) and software wait-states count.

There are 2 registers per memory space, making it possible to define 2 sets of boundaries and wait state numbers.

Figure 12.1 Default and user mapping examples

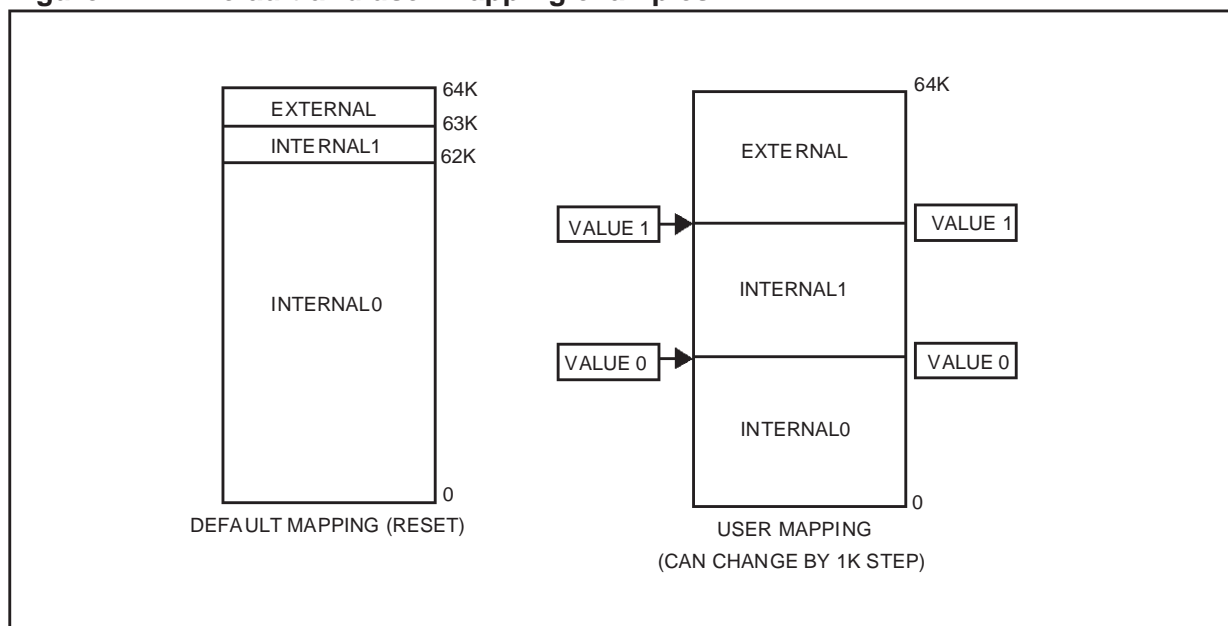

The BSU control registers include a reference address on bits 4 to 9, where the internal/external memory boundary value is stored (see Figure 12.1), and software wait-states count on bits 0 to 3, allowing up to 16 wait-states.

External addressing is recognized by comparing these address bits for each valid address from IA, XA and YA, to the reference address contained into the corresponding control register.

If the address is greater or equal to the reference value, an external access proceeds.

XER0/1: X-memory space control registers

After reset, XER0/1 default values are 0x83EF/0x83FF

15	14	13	12	11	10	9	8	7	6	5	4	3	2	1	0
IM	EN_X	-	-	-	-	XA15	XA14	XA13	XA12	XA11	XA10	W3	W2	W1	W0

Bit	Function
W3:0	Wait state count (1 to 16) for off-chip access (X-memory space)
XA15:10	X-memory space map for boundary on-chip or off-chip
EN_X	Enable for X-space data exchanges
IM	Intel/Motorola 0: Motorola type for memories 1: Intel type for memories (default)
-	RESERVED. Read 0, write don't care.

YER0/1: Y-memory space control registers

After reset, YER0/1 default values are 0x83EF/0x83FF

15	14	13	12	11	10	9	8	7	6	5	4	3	2	1	0
IM	EN_Y	-	-	-	-	YA15	YA14	YA13	YA12	YA11	YA10	W3	W2	W1	W0

Bit	Function
W3:0	Wait state count (1 to 16) for off-chip access (Y-memory space)
YA15:10	Y-memory space map for boundary on-chip or off-chip
EN_Y	Enable for Y-space data exchanges
IM	Intel/Motorola 0: Motorola type for memories 1: Intel type for memories (default)
-	RESERVED. Read 0, write don't care.

IER0/1: Instruction memory control registers

After reset, IER0/1 default values are 0x83EF/0x83FF or 0xC3EF/0xC3FF (the EN_I value depends on the $\overline{\text{IDT_EN}}$ input value).

15	14	13	12	11	10	9	8	7	6	5	4	3	2	1	0
IM	EN_I	-	-	-	-	IA15	IA14	IA13	IA12	IA11	IA10	W3	W2	W1	W0

ST18-AU1

Bit	Function
W3:0	Wait state count (1 to 16) for off-chip access (I-memory space)
IA15:10	I-memory space map for boundary on-chip or off-chip
EN_I	Enable for I-space data exchanges
IM	Intel/Motorola 0: Motorola type for memories 1: Intel type for memories (default)
-	RESERVED. Read 0, write don't care.

13 CLOCKS AND TIMERS UNIT

The clocks and timers unit provides all the necessary clocks and timer controls for DSP processing, and all input/output operations. In addition, a 90 kHz System Time Clock (STC) is provided to assist audio/video synchronization in systems which include a video decoder.

13.1 Operation

13.1.1 Audio clock prescaler

- inputs
 - AUDIOCLK: output of Audio Master clock PLL
 - MCLK_MODE: select internal or external Audio System Clock: (If bit CLK_sel1 of register PSCTR='0')
 - 0 = internal
 - 1 = external
- outputs
 - MCLK_PCM to PCM Output interface
 - MCLK_DIN to Data Input interface
- input/output
 - SCLK

The programmable prescaler and clock dividers of Data Input and PCM Output interfaces are used for the generation of data bit clocks.

The prescaler divide range is 1 to 510. It is defined by the content of the PSCTR register. Its output SCLKINT is a 50% duty cycle signal.

13.2 Clocks and timers registers

PSCTR register)

15	14	13	12	11	10	9	8	7	6	5	4	3	2	1	0
-	-	-	-	-	-	CLK_sel 2	CLK_sel 1	SCLKINTDIV							

Bit	Function
SCLKINT-DIV	SCLKINTDIV prescaler divide factor 00000000 1 00000001 2 ... 11111111 510 $f_{SCLKINT} = \frac{f_{pll2}}{2(SCLKINTDIV)}$ if SCLKINTDIV \neq 00000000
CLK_sel1	PCM output clock select: 0 Hardware (MCLK_MODE pin) 1 Software (according to bit 9)
CLK_sel2	PCM Output Clock select: 0 MCLK_PCM= output of prescaler: SCLK is system clock output 1 MCLK_PCM= SCLK: SCLK is system clock input
-	RESERVED, read as 0.

STC: system time clock registers

- input = EXTAL1 (27 MHz)
- output = STC

A Prescaler divides by 300 the master clock and generates the input clock at 90 KHz for STC. The 90 KHz clock is synchronized to the D950 instruction clock.

STC is a 32-bit counter incremented at each 90 KHz clock pulse. It can be initialized to any value and read by the D950. It is memory mapped as two registers, STCMTR and STCLTR.

STCMTR: 16-bit (MSB)

STCLTR: 16 bit (LSB)

Note: When initializing the STC, the STCLTR register must be written before the STCLMTR. The effective loading of the STC occurs after STCMTR loading: When reading the STC, the STCLTR register must be read first. At that time, the current value of the STC MSB is stored in the STCMTR register, which can then be read.

No interrupts are associated with the STC.

BLKCLKTR: block clock timer register

- input = FS (Samples Frequency)
- output = BLKCLK_IRQ

The **BLKCLKTR** register is a 16-bit decremter. It can be initialized to any value by the D950. An interrupt request is generated when the BLKCLKTR register is decremented to 0 and it is reset to its initial value.

SPDIF Timer register

- input = FS (Samples Frequency)
- output = SPDIF_IRQ

The SPDIFTR register is a 16-bit decremter. It can be initialized to any value by the D950. An interrupt request is generated when it is decremented to 0 and reset to its initial value.

Figure 13.1 Clocks and timers block diagram

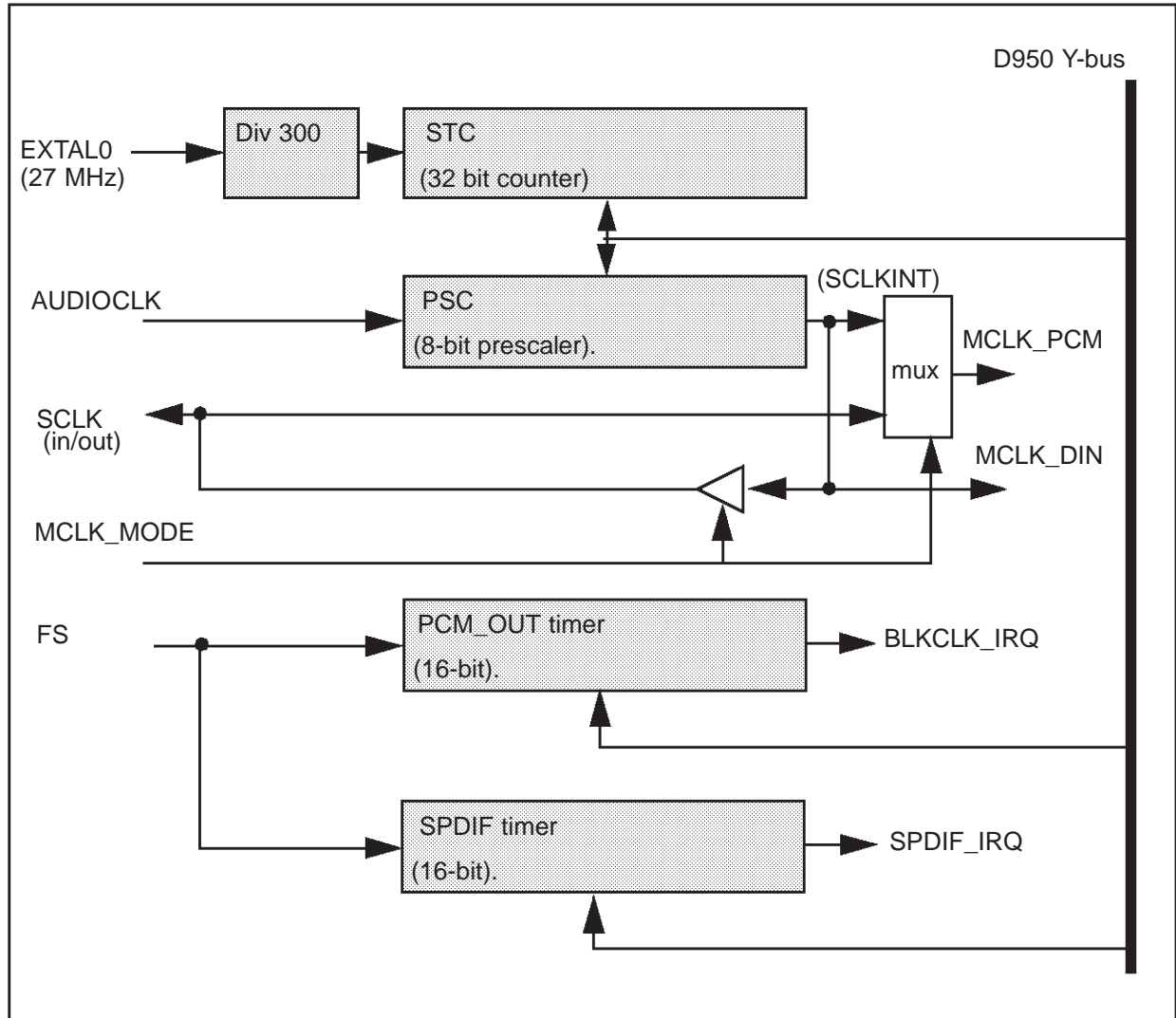

14 JTAG IEEE 1149.1 TEST ACCESS PORT

The Test Access Port (TAP) conforms to IEEE standard 1149.1.

The TAP consists of five pins: **TMS**, **TCK**, **TDI**, **TDO** and $\overline{\text{TRST}}$. **TDO** can be overdriven to the power rails, and **TCK** can be stopped in either logic state.

The instruction register is 8 bits long, with no parity, and the pattern "00000001" is loaded into the register during the *Capture-IR* state.

There are three defined public instructions, see Table 14.1. All other instruction codes are reserved.

Table 14.1 Instruction codes

Instruction code ¹⁾	Instruction	Selected register
04h	IDCODE	Identification
08h	EMU	D950 IOscan
FFh	BYPASS	Bypass

1) MSB... LSB; LSB closest to **TDO**

15 EMULATION UNIT

The emulation unit (EMU) performs functions dedicated to emulation and test through the external IEEE 1149.1 JTAG interface. Refer to Chapter 14 for details on the JTAG test access port.

The emulation and test operations are controlled by the JTAG Test Access Port (TAP) and the emulator by means of dedicated control I/Os.

Emulation mode can be entered in one of two ways:

- Asserting $\overline{\text{ERQ}}$ input pin low.
- Meeting a valid breakpoint condition or executing an instruction in single step mode.

The PC board emulator is able to display the processor status (memories and registers) and restore the context.

The emulation resources (see Figure 15.1) include:

- Four breakpoint registers (BP0-3) which can be affected by Program or Data memory.
- Breakpoint counter (BPC).
- Program counter trace buffer (PCB) able to store the address of the 6 last executed instructions.
- Three control registers for breakpoint condition programming (BC0-1 and ECS).
- Control logic for instruction execution through the PC-board emulator control.

Figure 15.1 Emulation block diagram

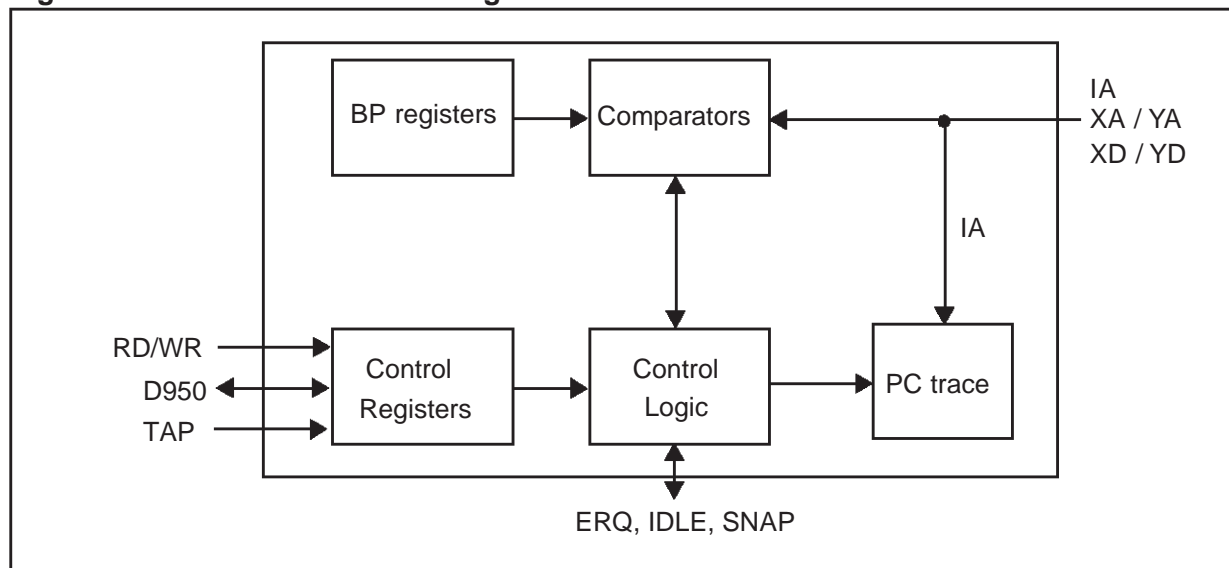

The emulation controller interface (see Table 2.12 and Table 2.13 on page 11) includes pins of different types:

- $\overline{\text{ERQ}}$, IDLE and SNAP are used by the emulator tools.
- HALTACK indicates that the processor is halted in emulation mode.

16 D950Core

The D950Core is composed of three main units.

- Data Calculation Unit (DCU)
- Address Calculation Unit (ACU)
- Program Control Unit (PCU)

For full details of the D950 DSP core refer to the D950Core datasheet (*document number 42-1709*).

These units are organized in an HARVARD architecture around three bidirectional 16-bit buses, two for data and one for instruction. Each of these buses is dedicated to an uni-directional 16-bit address bus (XA/YA/IA).

An 8-bit general purpose parallel port (P0-P7) can be configured (input or output). A test condition is attached to each bit to test external events.

The D950Core is controlled through interface pins related to interrupt, low-power mode, reset and miscellaneous functions.

Figure 16.1 D950Core block diagram

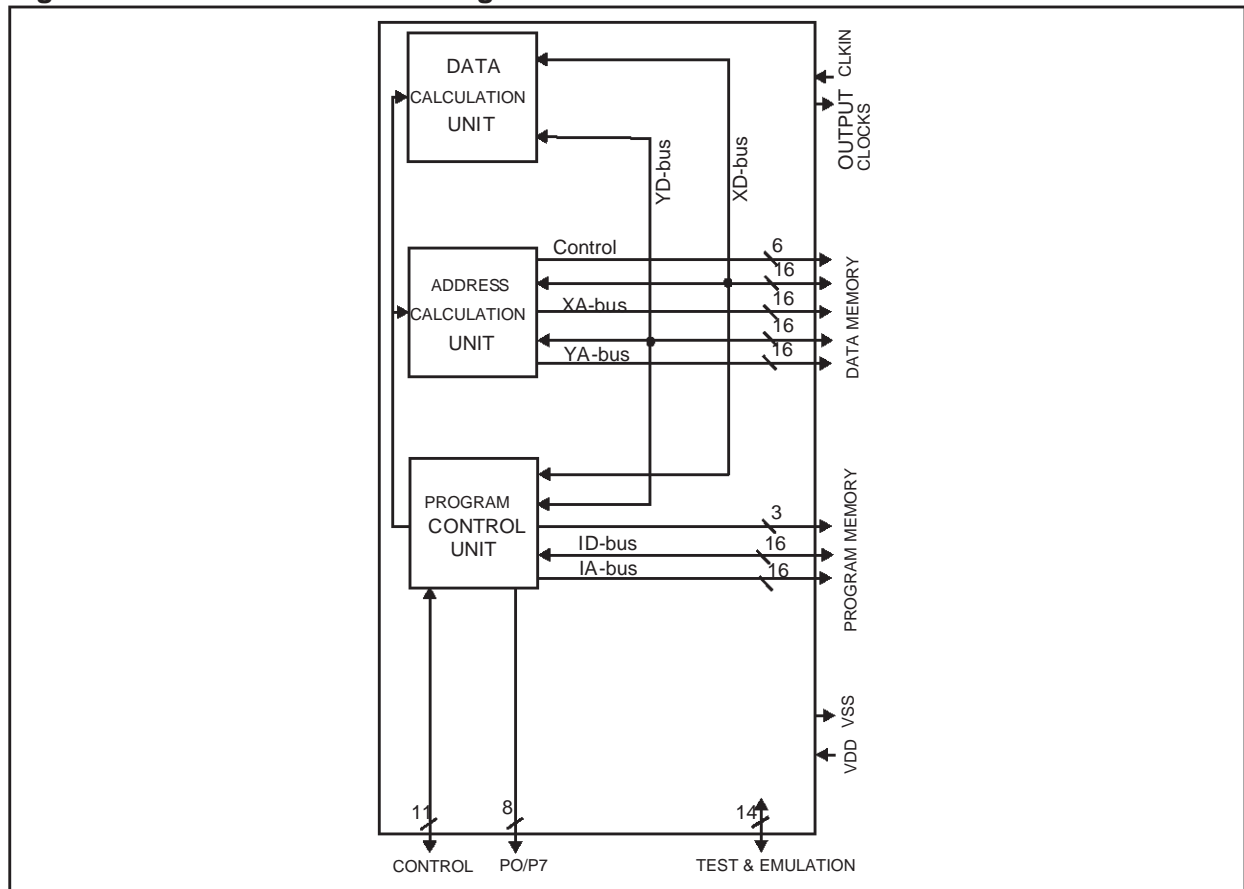

Data buses (XD/YD and XA/YA) are provided externally. Data memories (RAM, ROM) and peripherals registers are mapped in these address spaces.

Instruction bus (ID/IA) gives access to program memory (RAM, ROM). Each bus has its own control interface.

Table 16.1 Data/Instruction bus and corresponding address bus.

Data/Instruction bus			Corresponding address bus		
XD	Bidirectional	16-bit	XA	Unidirectional	16-bit
YD	Bidirectional	16-bit	YA	Unidirectional	16-bit
ID	Bidirectional	16-bit	IA	Unidirectional	16-bit

Depending on the calculation mode, the D950Core DCU computes operands which can be considered as 16 or 32-bit, signed or unsigned. It includes a 16 x 16-bit parallel multiplier able to implement MAC-based functions in one cycle per MAC. A 40-bit arithmetic and logic unit, including an 8-bit extension for arithmetic operations, implements a wide range of arithmetic and logic functions. A 40-bit barrel shifter unit and a bit manipulation unit are included.

The tables below illustrate the different types of word length and word format available for manipulation.

Table 16.2 Summary of possible word lengths and formats

0	1-bit word
7 0	8-bit word
15 0	16-bit word signed / unsigned
31 16 15 0	32-bit word signed / unsigned
39 32 31 16 15 0	40-bit word signed / unsigned

Format		Minimum	Maximum
fractional	signed	- 1	+ 0.999969481
	unsigned	0	+ 0.99996948
integer	signed	- 32768	+ 32767
	unsigned	0	+ 65535

16.1 D950Core registers

Register	Function
BX	Modulo base address for X-memory space
MX	Modulo maximum address for X-memory space
BY	Modulo base address for Y-memory space
MY	Modulo maximum address for Y-memory space
POR	Port Output Register - 8LSB are significant, 8MSB are undefined when reading
PIR	Port Input Register
PCDR	Port Control Direction Register
PCSR	Port Control Sensitivity Register
PPR	Program Page Register

PCDR

The Port Control Direction register defines the data direction of each port pin. After reset, PCDR default value is 0 (Port pins are configured as inputs)

15	14	13	12	11	10	9	8	7	6	5	4	3	2	1	0
-	-	-	-	-	-	-	-	P7D	P6D	P5D	P4D	P3D	P2D	P1D	P0D

Bit	Function
PiD	Port pin direction 0: Input port pin (default) 1: Output port pin
Bits 8 - 15	RESERVED (read: undefined, write: don't care)

PCSR

The Port Control Sensitivity register defines sensitivity of each port pin. After reset, PCSR default value is 0 (Port pins are configured as level-sensitive).

15	14	13	12	11	10	9	8	7	6	5	4	3	2	1	0
-	-	-	-	-	-	-	-	P7S	P6S	P5S	P4S	P3S	P2S	P1S	P0S

Bit	Function
PiS	Port pin sensitivity 0: Level sensitive (default) 1: Edge sensitive
Bits 8 - 15	RESERVED (read: undefined, write: don't care)

17 Y SPACE MEMORY MAPPING

17.1 Memory map

Figure 17.1 ST18-AU1 memory mapping

RESERVED	FFFF 2000
Internal Y RAM	1FFF 0100
RESERVED	00FF 00B5
Clocks and timers	00B4 00B0
RESERVED	00AF 00A6
S/PDIF	00A5 00A0
RESERVED	009F 009D
PCM output	009C 0090
RESERVED	008F 0084
Input/output buffer	0083 0080
RESERVED	007F 007B
Serial input 1	007A 0078
Serial input 0	0076 0070
RESERVED	006F 0064
Host interface	0063 0060
RESERVED	005F 0056

Bus switch unit	0055 0050
RESERVED	004F 004A
PLL	0049 0048
RESERVED	0047 0043
DMA controller	0042 0030
RESERVED	002F 002D
Interrupt controller	002C 0020
RESERVED	001F 0019
Emulator peripheral	001F 0010
D950 core	000F 0000

17.2 Clocks and timers registers

Address (Hex)	Register	Description
00B0	PSCTR	Prescaler
00B1	STCLTR	System Time Clock LSB
00B2	STCMTR	System Time Clock MSB
00B3	BLKCLKTR	Block Clock Timer
00B4	SPDIFTR	SPDIF Timer

17.3 IEC-958 transmitter (S/PDIF output) registers

Address (Hex)	Register	Description
00A0	SPDIFCR	SPDIF Control
00A1	SPDIFPR0	SPDIF Data0
00A2	SPDIFPR1	SPDIF Data1
00A3	SPDIFPR2	SPDIF Data2
00A4	CHANSTA1	Channel Status word1
00A5	CHANSTA2	Channel Status word2

17.4 PCM registers

Address (Hex)	Register	Description
0090	PCMCR	PCM Output Control
0091	PCMPR00	PCM Output Data 00
0092	PCMPR01	PCM Output Data 01
0093	PCMPR02	PCM Output Data 02
0095	PCMPR10	PCM Output Data 10
0096	PCMPR11	PCM Output Data 11
0097	PCMPR12	PCM Output Data 12
0099	PCMPR20	PCM Output Data 20
009A	PCMPR21	PCM Output Data 21
009B	PCMPR22	PCM Output Data 22
009C	PCMDIV	PCM Output Clock divide factor

17.5 Input/output buffer registers

Address (Hex)	Register	Description
0080	BUFCR	In/Out Buffer Control
0081	BUFSR	In/Out Buffer Status
0082	INBUFRAR	Input Buffer Read Address
0083	OUTBUFWAR	Output Buffer Write Address

17.6 Serial input 1 registers

Address (Hex)	Register	Description
0078	DIN1CR	Data In 1 Control
0079	DIN1DIV	Data In 1 Divide factor
007A	DIN1DR	Data In 1 Output

17.7 Serial input 0 registers

Address (Hex)	Register	Description
0070	DIN0CR	Data In 0 Control
0071	DIN0DIV	Data In 0 Divide factor
0072	FIFO CR	FIFO Control
0073	FIFO SR	FIFO Status
0074	FIFO Out	FIFO output
0075	FORM	Formatter
0076	PDCR	Packet Data Count

17.8 Host interface registers

Address (Hex)	Register	Description
0060	HCR	Host Interface Control
0061	HSR	Host Interface Status
0062	HSAR	Slave Address
0063	HDR	Host Data Register

17.9 Bus switch unit registers

Address (Hex)	Register	Description
0055	YER1	External Y-bus control register 1
0054	XER1	External X-bus control register 1
0053	IER1	External I-bus control register 1
0052	YER0	External Y-bus control register 0
0051	XER0	External X-bus control register 0
0050	IER0	External I-bus control register 0

17.10 PLL registers

Address (Hex)	Register	Description
0048	D950_PllDiv	D950_Pll divide factor
0049	Audio_PllDiv	Audio_Pll divide factor

17.11 DMA controller registers

Address (Hex)	Register	Description
0042	DAIC	DMA address / interrupt control
0041	DMS	DMA mask sensitivity
0040	DGC	DMA general control
003F	DCC3	DMA channel 3 current count
003E	DCC2	DMA channel 2 current count
003D	DCC1	DMA channel 1 current count
003C	DCC0	DMA channel 0 current count
003B	DIC3	DMA channel 3 initial count
003A	DIC2	DMA channel 2 initial count
0039	DIC1	DMA channel 1 initial count
0038	DIC0	DMA channel 0 initial count
0037	DCA3	DMA channel 3 current address
0036	DCA2	DMA channel 2 current address
0035	DCA1	DMA channel 1 current address
0034	DCA0	DMA channel 0 current address
0033	DIA3	DMA channel 3 initial address
0032	DIA2	DMA channel 2 initial address
0031	DIA1	DMA channel 1 initial address
0030	DIA0	DMA channel 0 initial address

17.12 Interrupt controller registers

002C	ISR	Interrupt status register
002B	ISPR	Interrupt stack pointer register
002A	IPR	Interrupt priority register
0029	IMR	Interrupt mask/sensitivity register
0028	ICR	Interrupt control register
0027	IV7	Interrupt vector 7 address
0026	IV6	Interrupt vector 6 address
0025	IV5	Interrupt vector 5 address
0024	IV4	Interrupt vector 4 address
0023	IV3	Interrupt vector 3 address
0022	IV2	Interrupt vector 2 address
0021	IV1	Interrupt vector 1 address
0020	IV0	Interrupt vector 0 address

17.13 D950 core control registers

Address (Hex)	Register	Description
0007	PCSR	Port control sensitivity register
0006	PCDR	Port control direction register
0005	PIR	Port input register
0004	POR	Port output register
0003	MY	Y-memory space modulo max address
0002	BY	Y-memory space modulo base address
0001	MX	X-memory space modulo max address
0000	BX	X-memory space modulo base address

17.14 Data and program memory mapping

X Memory mapping

address (Hex)	Name	Function
0000 to 3FFF		On chip X RAM (16K words).

Y Memory mapping

address (Hex)	Name	Function
007F to 1FFF		On chip Y RAM (7936 words). Addresses 00 to FF (256 words) reserved for D950 and peripherals memory mapped registers.

I Memory mapping

I address (Hex)	Name	Function
0000 to 3FFF		On chip I RAM (16K words)

18 ELECTRICAL SPECIFICATIONS

In the following tables TBD indicates 'to be defined'.

18.1 DC Absolute maximum ratings

Table 18.1 DC absolute maximum ratings

Symbol	Parameter	Value	Unit
VDD	Power supply voltage	- 0.5 / 4	V
Vin	Input voltage	-0.5 / Vdd+0.5	V
Ta	Operating temperature range	0 / +70	°C
Tstg	Storage temperature range	-55 / +150	°C

18.2 DC Electrical characteristics

Table 18.2 DC electrical characteristics

Symbol	Parameter	Min	Typ	Max	Unit	Notes
V _{DD}	Supply voltage	2.7	3.3	3.6	V	
V _{IL}	Input low level	-0.3		0.8	V	
V _{IH}	Input high level	2.0		VDD+0.3v	V	
I _{IN}	Input current			±10	µA	
V _{OL}	Output low level			0.4	V	1
V _{OH}	Output high level	2.4			V	1
I _{DD}	Operating current		180		mA	

Notes 1: Iload = 2mA

18.3 AC characteristics

The following timings are based on simulations and may change when full characterisation is completed.

Figure 18.1 Input waveforms

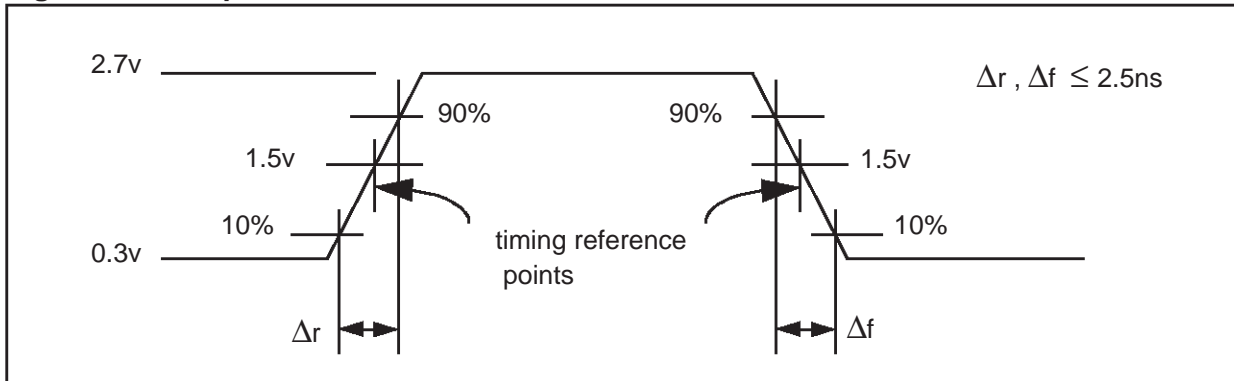

Figure 18.2 Output load circuit and waveform

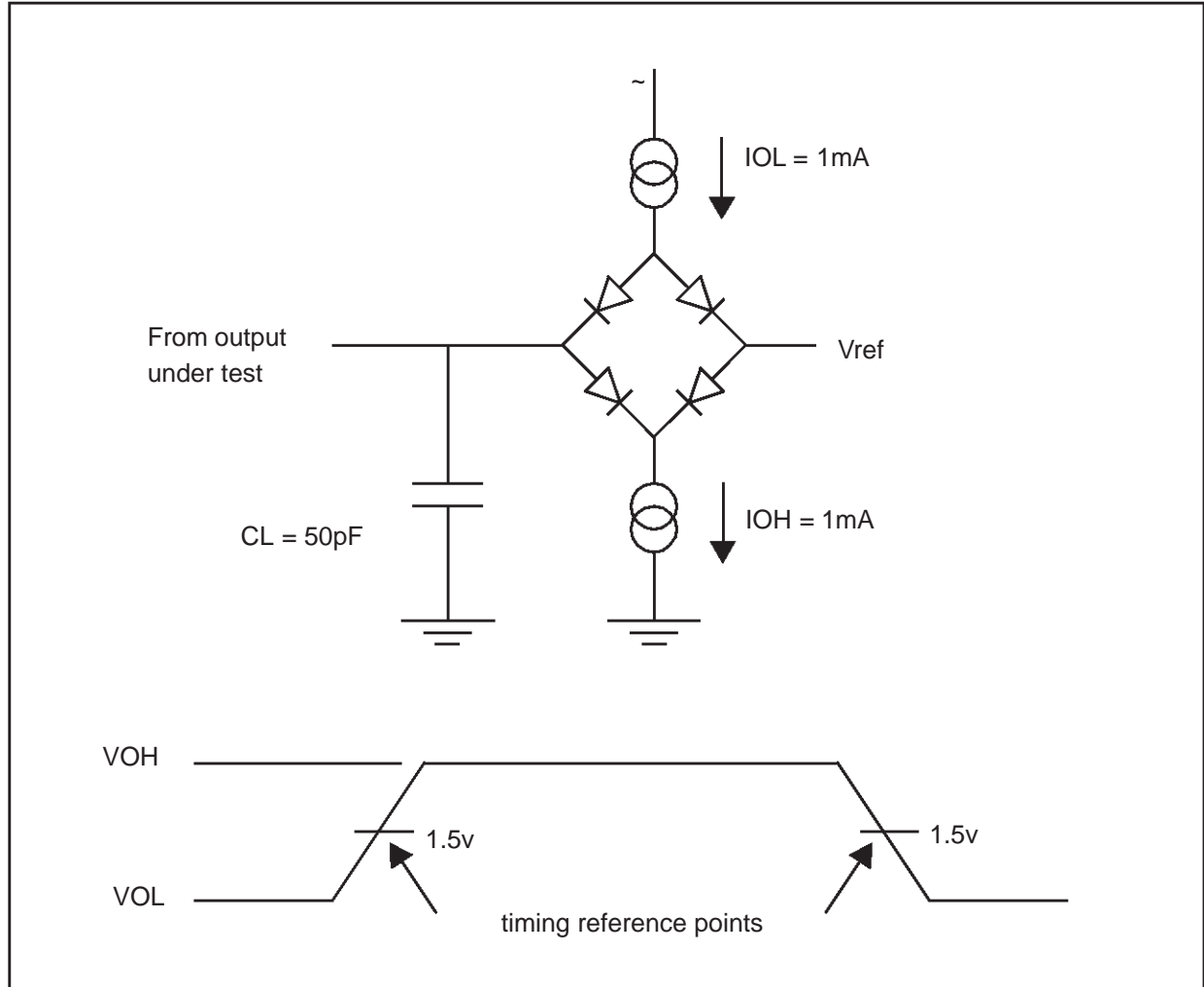
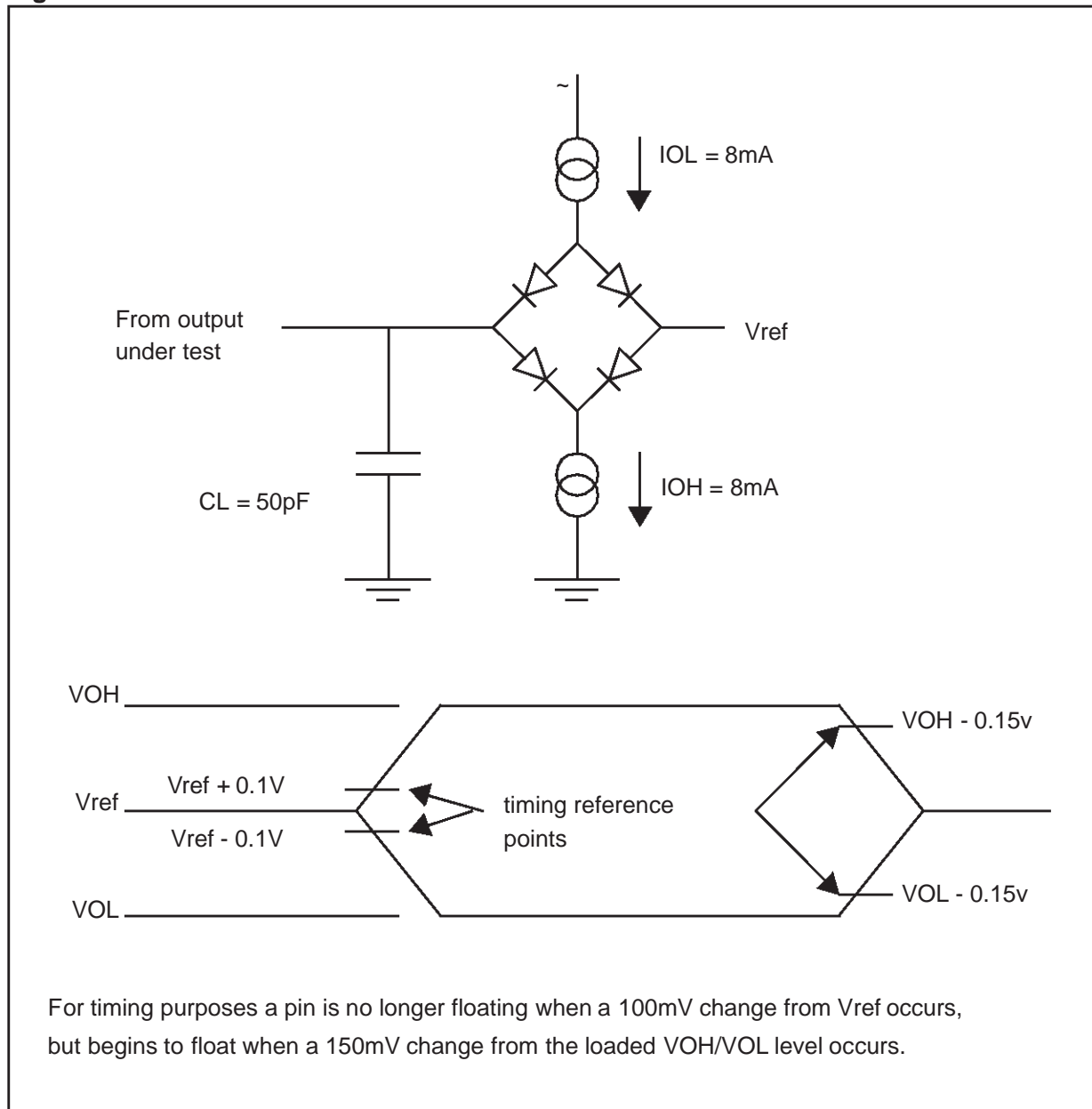

Table 18.3 AC measurement conditions - input only or output only pins

V_{DD}	V_{IL}	V_{IH}	V_{OL}	V_{OH}	I_{OL}	I_{OH}
VDDmin	0.3v	2.7v	1.5V	1.5V	1mA	1mA
VDDmax	0.3v	2.7v	1.5V	1.5V	1mA	1mA

Figure 18.3 Float load circuit and waveform



18.3.1 Clocks electrical characteristics

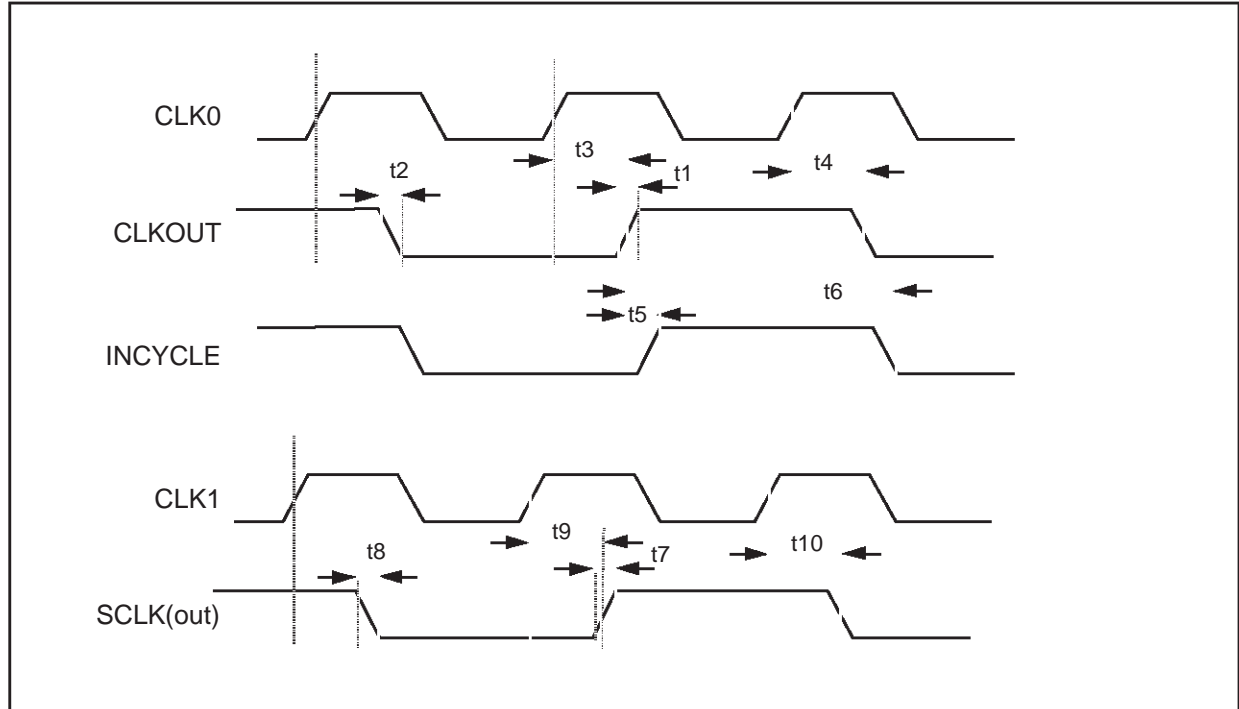

No	Parameter	Min (ns)	Typ (ns)	Max (ns)
t1	CLKOUT rise time			
t2	CLKOUT fall time			
t3	CLKOUT high delay(1)		7.05	
t4	CLKOUT low delay(1)		6.95	
t5	INCYCLE high delay		0.55	
t6	INCYCLE low delay		T0-0.7	
t7	SCLK out rise time			
t8	SCLK out fall time			
t9	SCLK out high delay(2)		6.25	
t9	SCLK out high delay(3)		7.10	
t10	SCLK out low delay(2)		6.75	
t10	SCLK out low delay(3)		7.70	

(1): CLK0_MODE=0 (Bypass PLL)

(2): CLK1_MODE=0 (Bypass PLL),MCLK_MODE=0 (select internal generation from CLK1)
 No divide option set.

(3):CLK1_MODE=0 (Bypass PLL),MCLK_MODE=0 (select internal generation from CLK1)
 Prescaler divide by 2

18.3.2 E-bus (I direct extension)

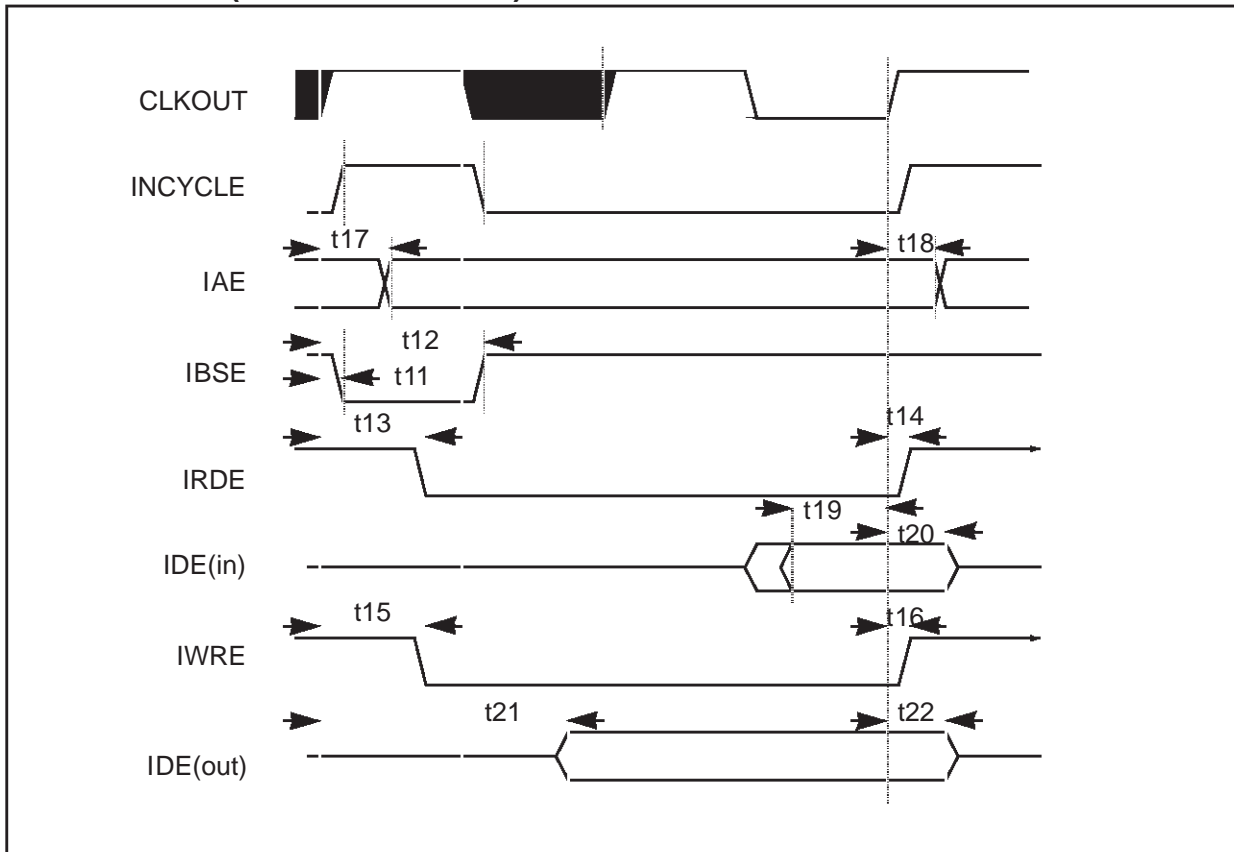

No	PARAMETER	Min (ns)	Typ (ns)	Max (ns)
t11	$\overline{\text{IBSE}}$ low delay		0.3	
t12	$\overline{\text{IBSE}}$ high delay		T0-1.4	
t13	$\overline{\text{IRDE}}$ low delay		T0/2-1.05	
t14	$\overline{\text{IRDE}}$ high delay		0.35	
t15	$\overline{\text{IWRE}}$ low delay		T0/2+0.9	
t16	$\overline{\text{IWRE}}$ high delay		0	
t17	IAE valid delay		1.6	
t18	IAE hold time		1.1	
t19	IDE (in) setup time		5.45	
t20	IDE (in) holdtime		-4.40	
t21	IDE (out) valid delay (Hi to Lo Z)		T0+3.80	
t22	IDE (out) valid delay (Lo to Hi Z)		-0.1	

18.3.3 E-bus (X direct extension)

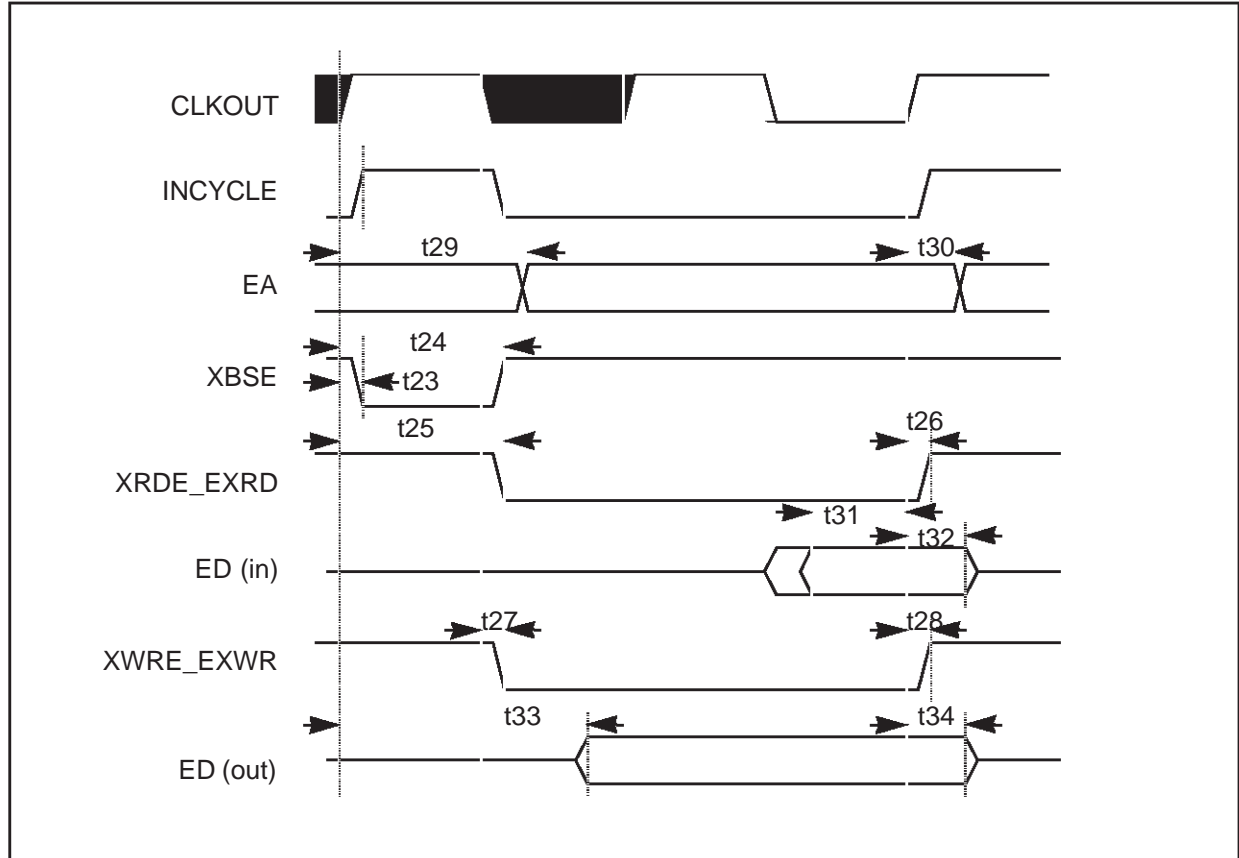

No	PARAMETER	Min (ns)	Typ (ns)	Max (ns)
t23	$\overline{\text{XBSE}}$ low delay		0.25	
t24	$\overline{\text{XBSE}}$ high delay		T0+0.3	
t25	$\overline{\text{XRDE_EXRD}}$ low delay		T0+2.5	
t26	$\overline{\text{XRDE_EXRD}}$ high delay		0.65	
t27	$\overline{\text{XWRE_EXWR}}$ low delay		T0+2.6	
t28	$\overline{\text{XWRE_EXWR}}$ high delay		0.35	
t29	EA valid delay		T0+3.95	
t30	EA hold time		3.30	
t31	ED (in) setup time		7.50	
t32	ED (in) hold time		-5.85	
t33	ED (out) valid delay (Hi to Lo Z)		T0+3	
t34	ED (out) valid delay (Lo to Hi Z)		0.3	

18.3.4 E-bus (I BSU)

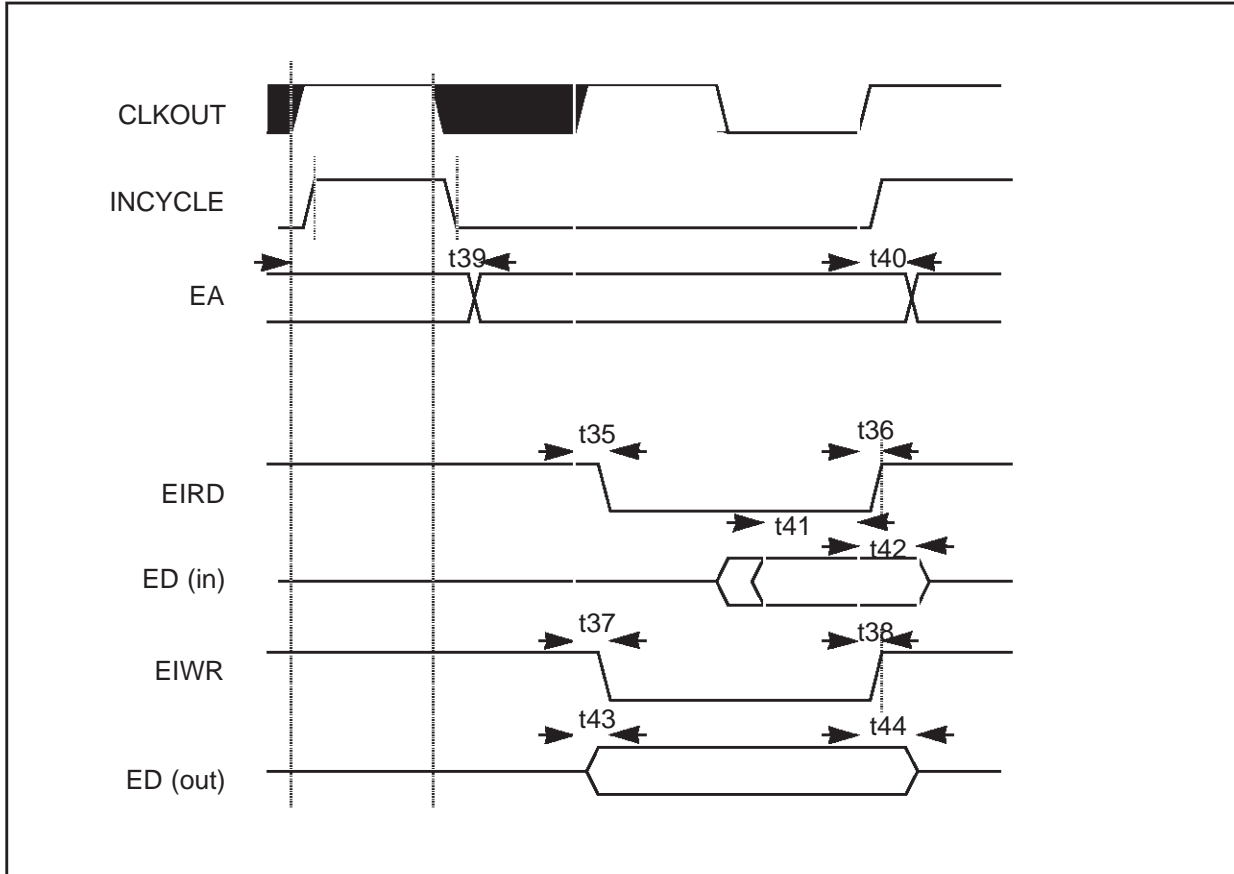

No	PARAMETER	Min (ns)	Typ (ns)	Max (ns)
t35	$\overline{\text{EIRD}}$ low delay		2.55	
t36	$\overline{\text{EIRD}}$ high delay		1.4	
t37	$\overline{\text{EIWR}}$ low delay		2.15	
t38	$\overline{\text{EIWR}}$ high delay		1.7	
t39	EA valid delay		$T_0+4.15$	
t40	EA hold time		$T_0+3.90$	
t41	ED (in) setup time		8.25	
t42	ED (in) hold time		-6.55	
t43	ED (out) valid delay (Hi to Lo Z)		2	
t44	ED (out) valid delay (Lo to Hi Z)		1.95	

18.3.5 E-bus (X BSU)

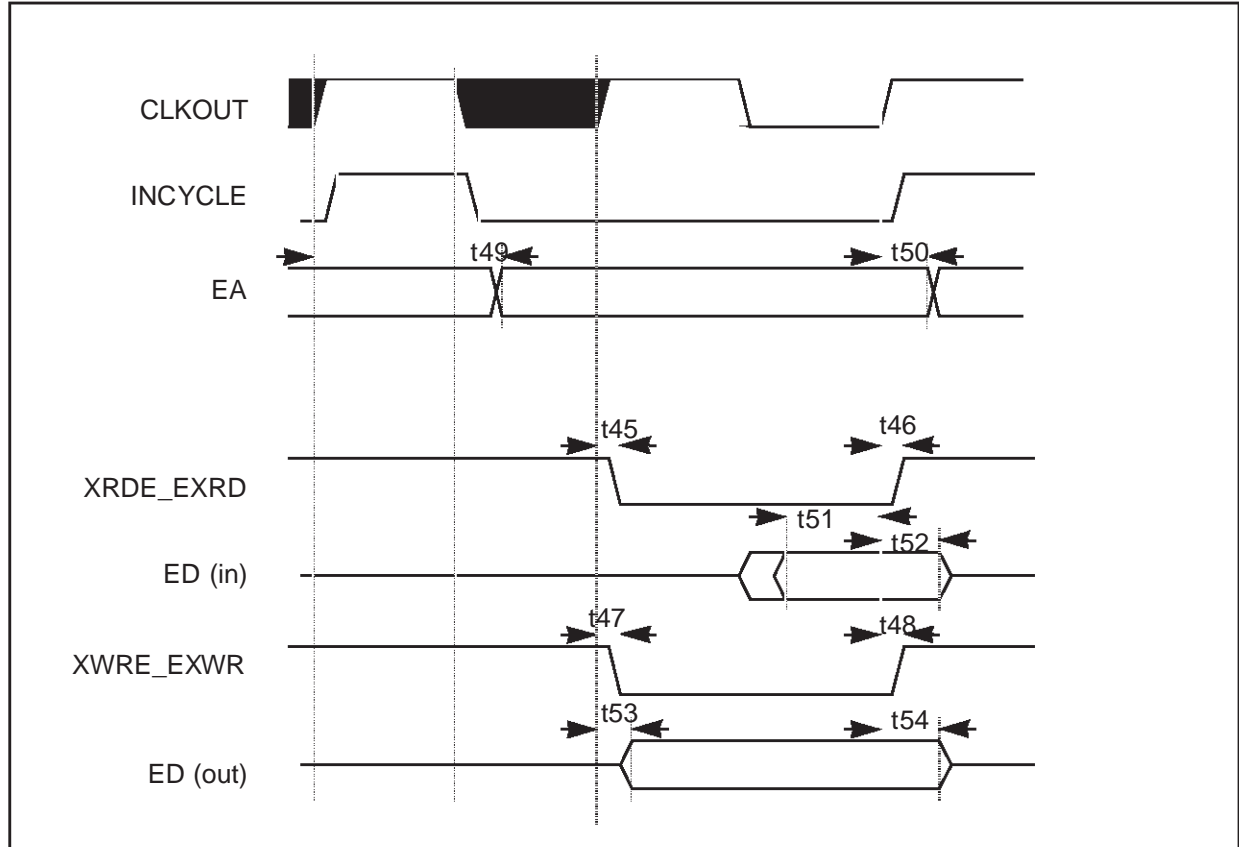

No	PARAMETER	Min (ns)	Typ (ns)	Max (ns)
t45	$\overline{\text{XRDE_EXRD}}$ low delay		3.65	
t46	$\overline{\text{XRDE_EXRD}}$ high delay		2	
t47	$\overline{\text{XWRE_EXWR}}$ low delay		3.15	
t48	$\overline{\text{XWRE_EXWR}}$ high delay		1.95	
t49	EA valid delay		T0+4.65	
t50	EA hold time		T0+4.40	
t51	ED (in) setup time		8.35	
t52	ED (in) hold time		-7.15	
t53	ED (out) valid delay (Hi to Lo Z)		4.85	
t54	ED (out) valid delay (Lo to Hi Z)		1.55	

18.3.6 E-bus (Y BSU)

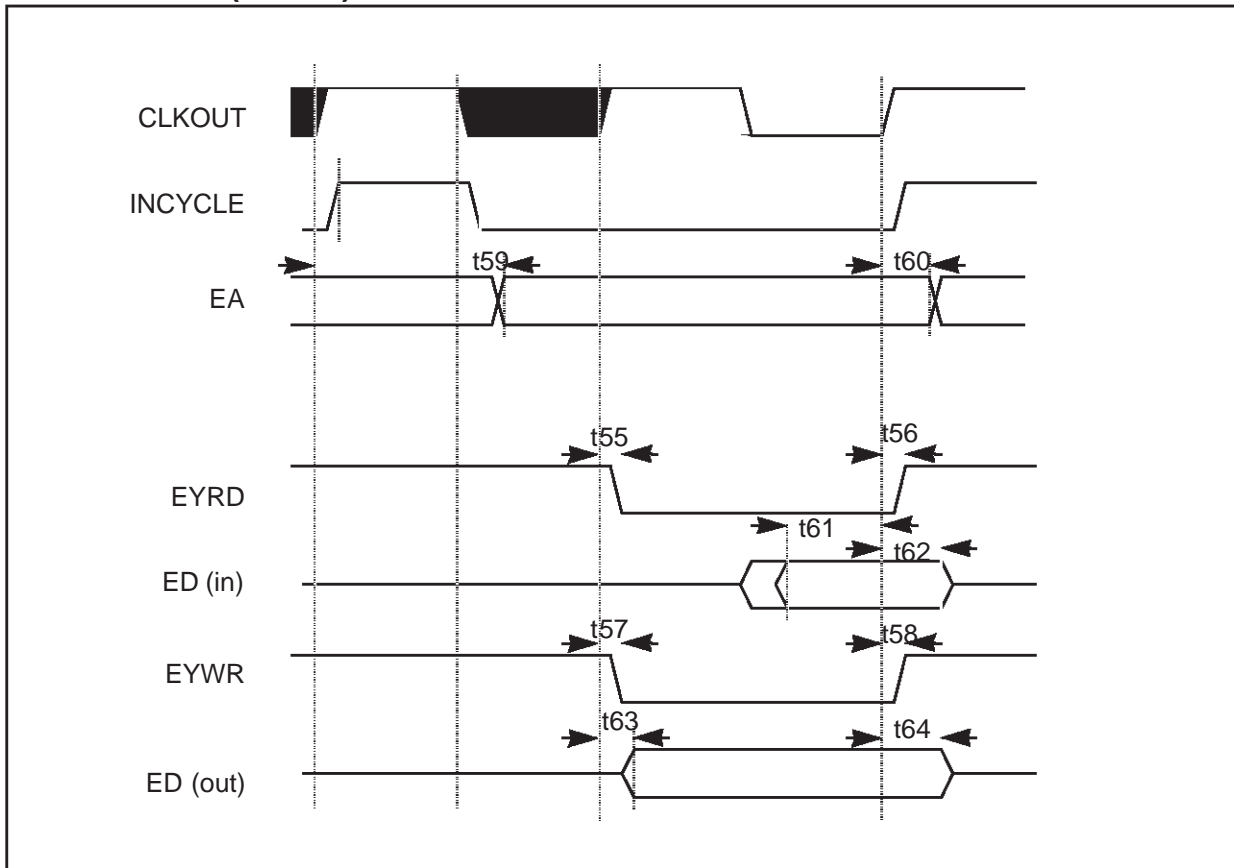

No	PARAMETER	Min (ns)	Typ (ns)	Max (ns)
t55	$\overline{\text{EYRD}}$ low delay		2.85	
t56	$\overline{\text{EYRD}}$ high delay		1.4	
t57	$\overline{\text{EYWR}}$ low delay		2.85	
t58	$\overline{\text{EYWR}}$ high delay		1.4	
t59	EA valid delay		T0+4.1	
t60	EA hold time		T0+4.05	
t61	ED (in) setup time		9.2	
t62	ED (in) hold time		-7.55	
t63	ED (out) valid delay (Hi to Lo Z)		4.20	
t64	ED (out) valid delay (Lo to Hi Z)		2.05	

18.3.7 D950 control

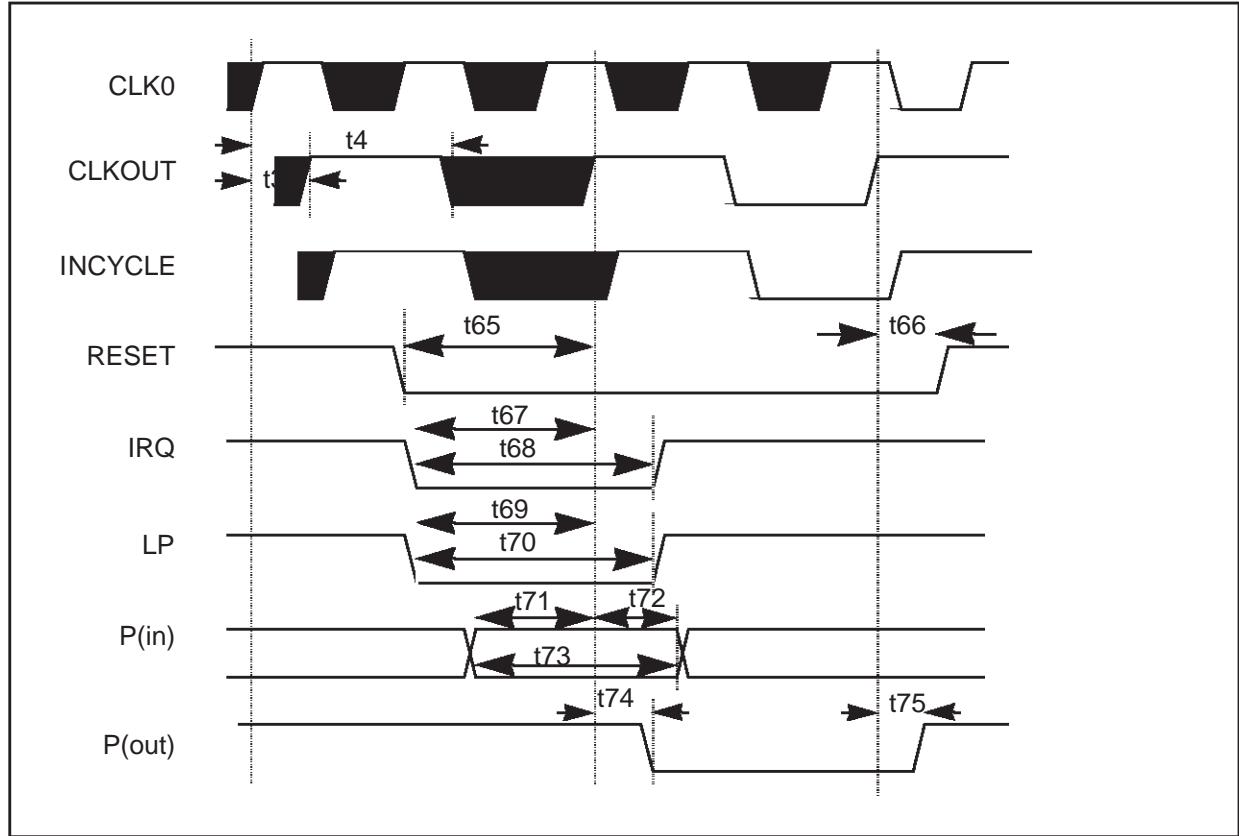

No	PARAMETER	Min (ns)	Typ (ns)	Max (ns)
t65	$\overline{\text{RESET}}$ setup time		8.30	
t66	$\overline{\text{RESET}}$ hold time			
t67	$\overline{\text{IRQ}}$ setup time		6	
t68	$\overline{\text{IRQ}}$ min. pulse duration,low			
t69	$\overline{\text{LP}}$ setup time		6.2	
t70	$\overline{\text{LP}}$ min. pulse duration,low			
t71	P (in) setup time		6.05	
t72	P (in) hold time		-5.85	
t73	P (in) min pulse duration,low (edge			
t74	P (out) low delay		2.6	
t75	P (out) high delay		3.0	

18.3.8 I2C Host interface

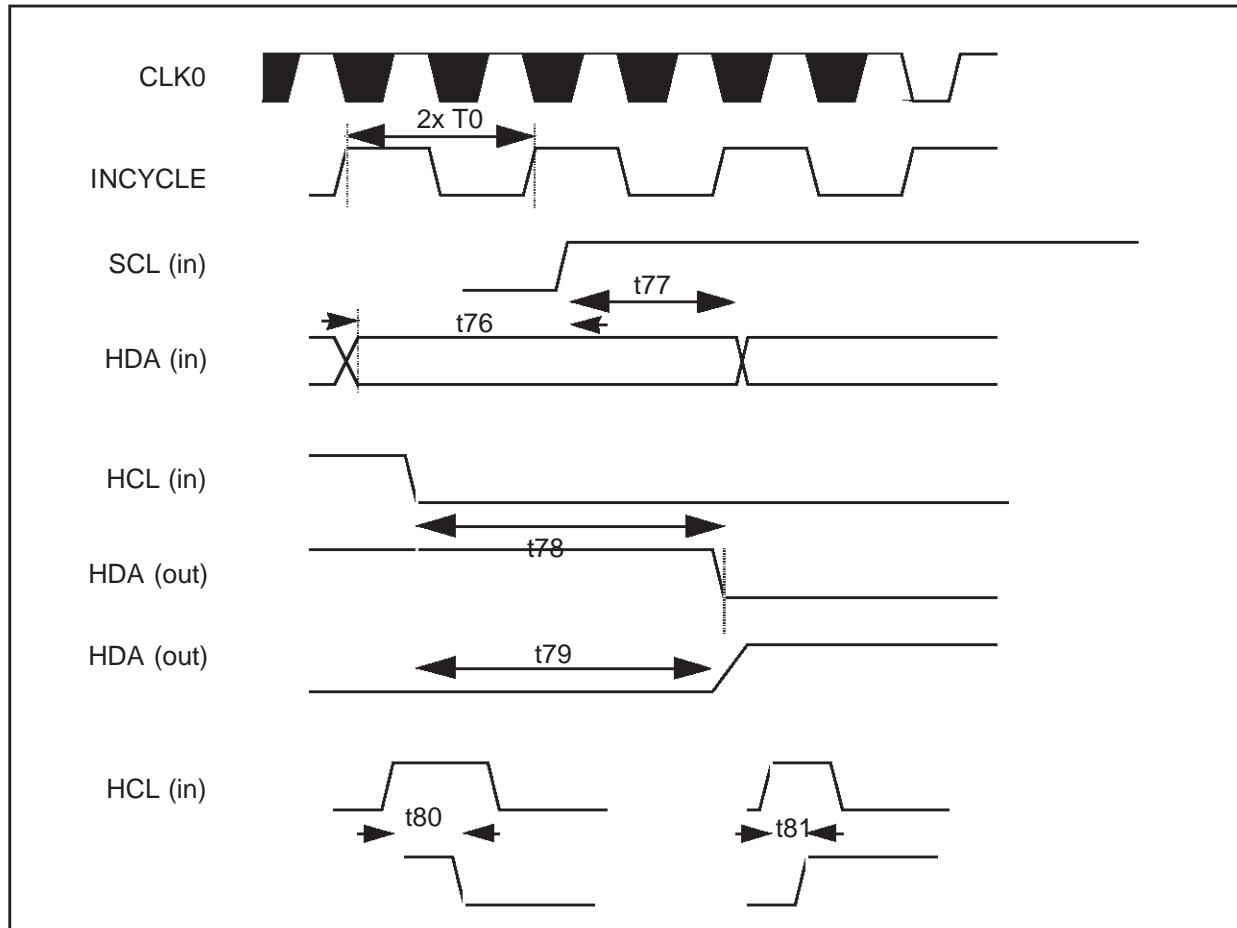

No	PARAMETER	Min (ns)	Typ (ns)	Max (ns)
t76	HDA (in) setup time vs SCLK		$2xT_0 + 1.1ns$	
t77	HDA (in) hold time vs SCLK		0	
t78*	HDA (out) low delay min		$2xT_0 + 6.45ns$	
	HDA (out) low delay max		$4xT_0 + 6.45ns$	
t79**	HDA (out) lo to Hi Z delay min		TBD	
	HDA (out) lo to Hi Z delay max		TBD	
t80	START Condition setup		TBD	
t81	STOP Condition setup		TBD	

* = External R load to Vdd =

** Rise time defined by External Rload

18.3.9 PCM and SPDIF

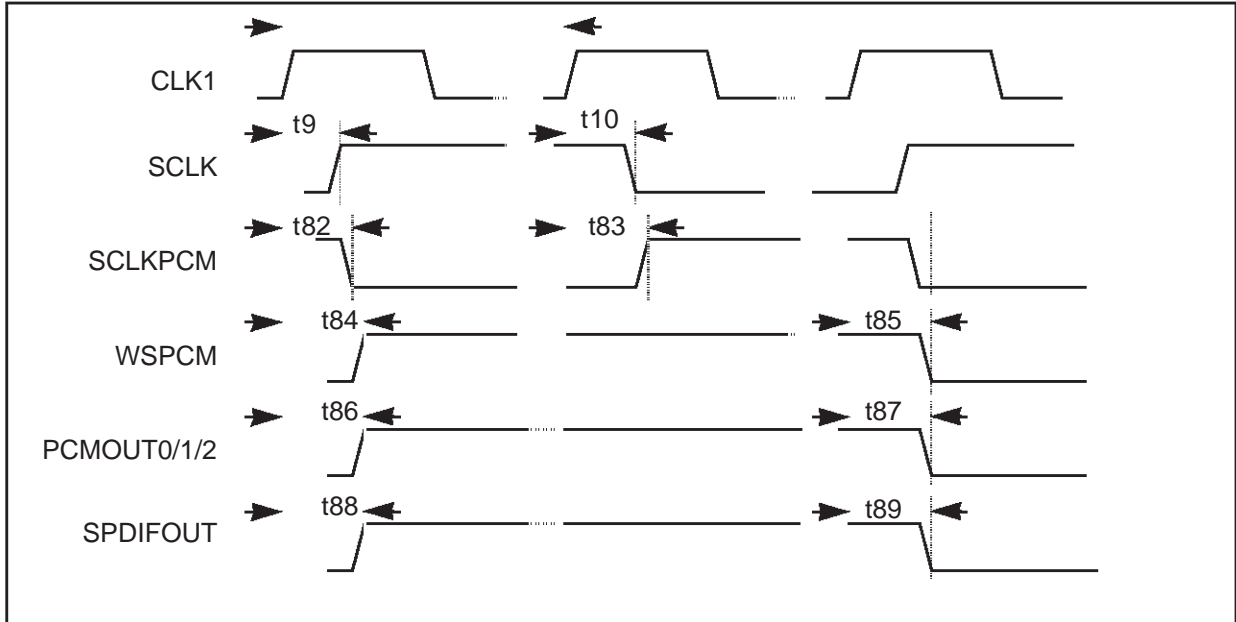

No	PARAMETER	Min (ns)	Typ (ns)	Max (ns)
t82*	SCLKPCM high delay		10.3	
t83*	SCLKPCM low delay		10.4	
t84	WSPCM high delay		11.4	
t85	WSPCM low delay		11.30	
t86	PCMOUT0/1/2 high delay		10.65	
t87	PCMOUT0/1/2 low delay		10.60	
t88	SPDIFOUT high delay		11.4	
t89	SPDIFOUT low delay		11.3	

* SCLKPCM generated from CLK1, Prescaler divide by 2

18.3.10 I2S Data Input 0

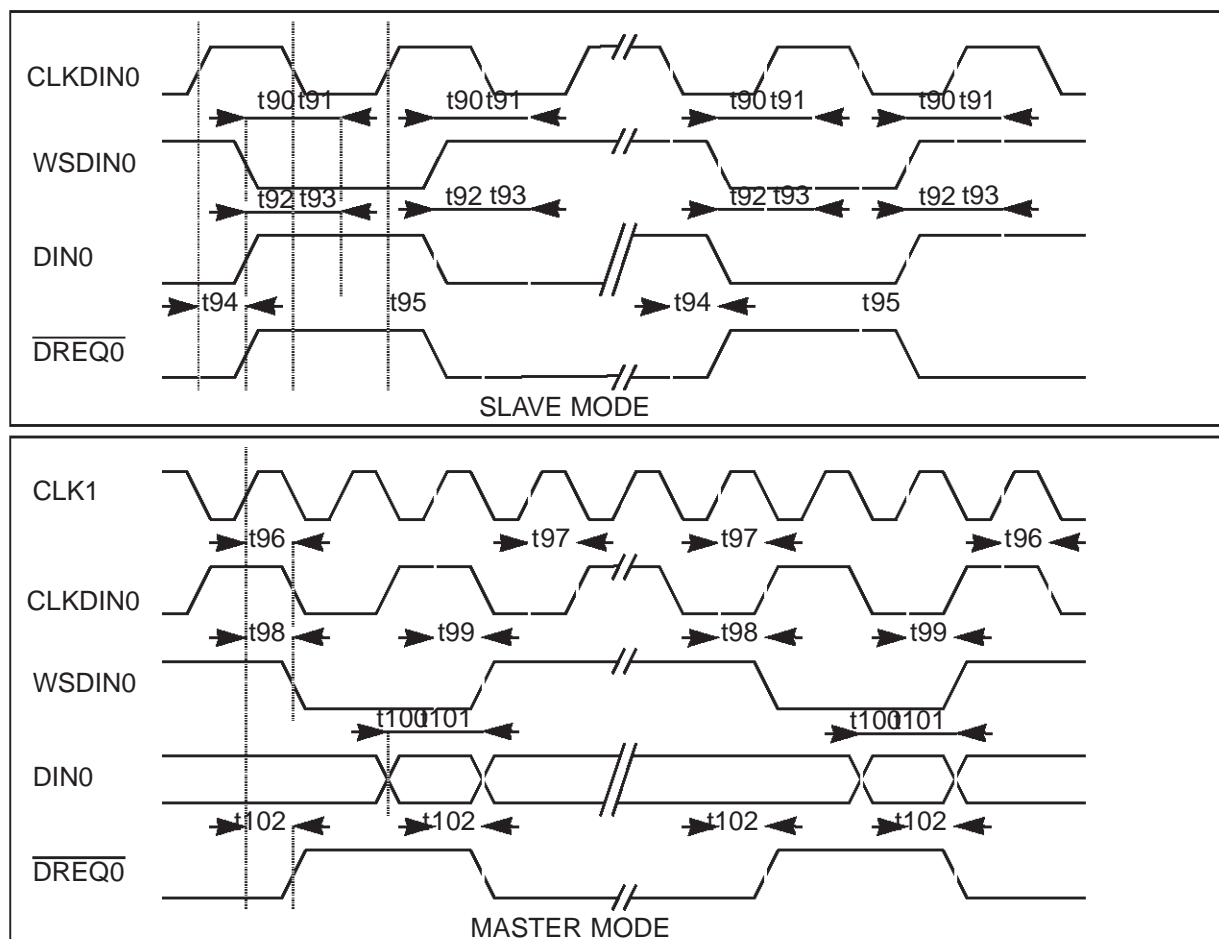

No	PARAMETER	Min (ns)	Typ (ns)	Max (ns)
t90	WSDIN0 to CLKDIN0 setup time		-1.45	
t91	CLKDIN0 to WSDIN0 hold time		2.10	
t92	DIN0 to CLKDIN0 setup time		-2.95	
t93	CLKDIN0 to DIN0 hold time		3.45	
t94	CLKDIN0 to $\overline{\text{DREQ0}}$ rise propagation time		7.05	
t95*	CLK0 rise to $\overline{\text{DREQ0}}$ fall propagation time		12.90	
t96	CLK1 rise to CLKDIN0 fall propagation time		9.70	
t97	CLK1 rise to CLKDIN0 rise propagation time		9.90	
t98	CLK1 rise to WSDIN0 fall propagation time		11	
t99	CLK1 rise to WSDIN0 rise propagation time		10.95	
t100	DIN0 to CLK1 rise setup time		-4.80	
t101	CLK1 rise to DIN0 hold time		-5.40	
t102	CLK1 rise to $\overline{\text{DREQ0}}$ propagation time		10.90	

* For this time, CLKDIN0 is halted by $\overline{\text{DREQ0}}$.

18.3.11 I2S Data Input 1

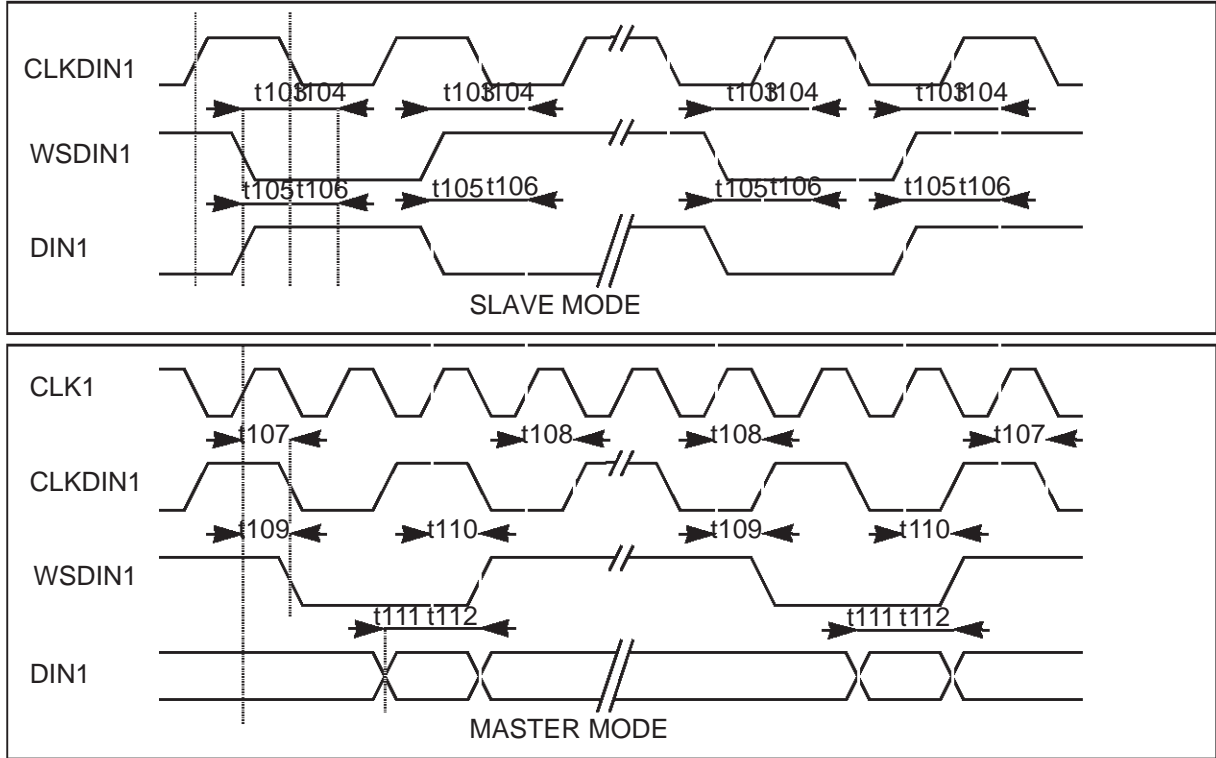

No	PARAMETER	Min (ns)	Typ (ns)	Max (ns)
t103	WSDIN1 to CLKDIN1 setup time		-1.6	
t104	CLKDIN1 to WSDIN1 hold time		1.4	
t105	DIN1 to CLKDIN1 setup time		-2.05	
t106	CLKDIN1 to DIN1 hold time		2.35	
t107	CLK1 rise to CLKDIN1 fall propagation time		9.50	
t108	CLK1 rise to CLKDIN1 rise propagation time		9.50	
t109	CLK1 rise to WSDIN1 fall propagation time		11.10	
t110	CLK1 rise to WSDIN1 rise propagation time		11.15	
t111	DIN1 to CLK1 rise setup time		-4.25	
t112	CLK1 rise to DIN1 hold time		4.56	

19 ST18-AU1 PACKAGE SPECIFICATIONS

19.1 ST18-AU1 package pinout

The ST18-AU1 is available in a 160 pin plastic quad flat pack (PQFP) package.

Table 19.1 ST18-AU1 package pinout

Pin name	Pin no.	Pin name	Pin no.	Pin name	Pin no.	Pin name	Pin no.
GNDE	1	VDD	41	VDDE	81	GND	121
VDDE	2	GND	42	GNDE	82	VDD	122
IDE<15>	3	VDDE	43	EA<0>	83	P<7>	123
IDE<14>	4	GNDE	44	EA<1>	84	P<6>	124
IDE<13>	5	PCM_OUT0	45	EA<2>	85	P<5>	125
IDE<12>	6	PCM_OUT1	46	EA<3>	86	P<4>	126
IDE<11>	7	PCM_OUT2	47	EA<4>	87	P<3>	127
IDE<10>	8	WSPCM	48	EA<5>	88	P<2>	128
IDE<9>	9	SCLKPCM	49	EA<6>	89	P<1>	129
IDE<8>	10	SPDIFOUT	50	EA<7>	90	P<0>	130
IDE<7>	11	IRDE	51	EA<8>	91	MODE_RESET	131
IDE<6>	12	IWRE	52	EA<9>	92	TDI	132
IDE<5>	13	GND	53	EA<10>	93	GND	133
IDE<4>	14	IBSE	54	VDDE	94	VDD	134
IDE<3>	15	INCYCLE	55	GNDE	95	IRQ	135
IDE<2>	16	CLKOUT	56	EA<11>	96	LP	136
IDE<1>	17	VDD	57	EA<12>	97	SCLK	137
GNDE	18	GND	58	EA<13>	98	HSAS	138
VDDE	19	VDD	59	EA<14>	99	HDA	139
VDD	20	GND	60	EA<15>	100	HCL	140
IDE<0>	21	MCLK_MODE	61	ED<0>	101	DREQ0	141
IAE<15>	22	CLK0	62	ED<1>	102	CLKDIN1	142
GND	23	CLK1	63	ED<2>	103	CLKDIN0	143
IAE<14>	24	CLK0_MODE	64	ED<3>	104	WSDIN1	144
IAE<13>	25	CLK1_MODE	65	ED<4>	105	WSDIN0	145
IAE<12>	26	PLL_MODE	66	VDDE	106	DIN1	146
IAE<11>	27	EXTAL0	67	GNDE	107	VDD	147
IAE<10>	28	VDD	68	ED<5>	108	GND	148
IAE<9>	29	EXTAL1	69	ED<6>	109	DIN0	149
IAE<8>	30	XTAL0	70	ED<7>	110	SNAP	150
IAE<7>	31	XTAL1	71	ED<8>	111	HALTACK	151
IAE<6>	32	XBSE	72	ED<9>	112	IDLE	152

ST18-AU1

Pin name	Pin no.	Pin name	Pin no.	Pin name	Pin no.	Pin name	Pin no.
IAE<5>	33	XRDE_EXRD	73	ED<10>	113	ERQ	153
IAE<4>	34	XWRE_EXWR	74	ED<11>	114	RESET	154
IAE<3>	35	EYWR	75	ED<12>	115	TMS	155
IAE<2>	36	EIWR	76	ED<13>	115	TDO	156
IAE<1>	37	EIRD	77	ED<14>	117	TCK	157
IAE<0>	38	EYRD	78	ED<15>	118	TRST	158
GNDE	39	VDD	79	VDDE	119	GND	159
VDDE	40	GND	80	GNDE	120	VDD	160

19.2 160 pin PQFP package dimensions

Table 19.2 160 pin PQFP package dimensions

REF.	TYP	MIN	MAX
A			4,07
A1		0,25	
A2	3,42	3,17	3,67
B		0,22	0,38
c		0,13	0,23
D	31,20	30,95	31,45
D1	28,00	27,90	28,10
D3	25,35		
e	0,65		
E	31,20	30,95	31,45
E1	28,00	27,90	28,10
E3	25,35		
L	0,80	0,65	0,95
L1	1,60		
k		0°	7°

Figure 19.1 Package diagram

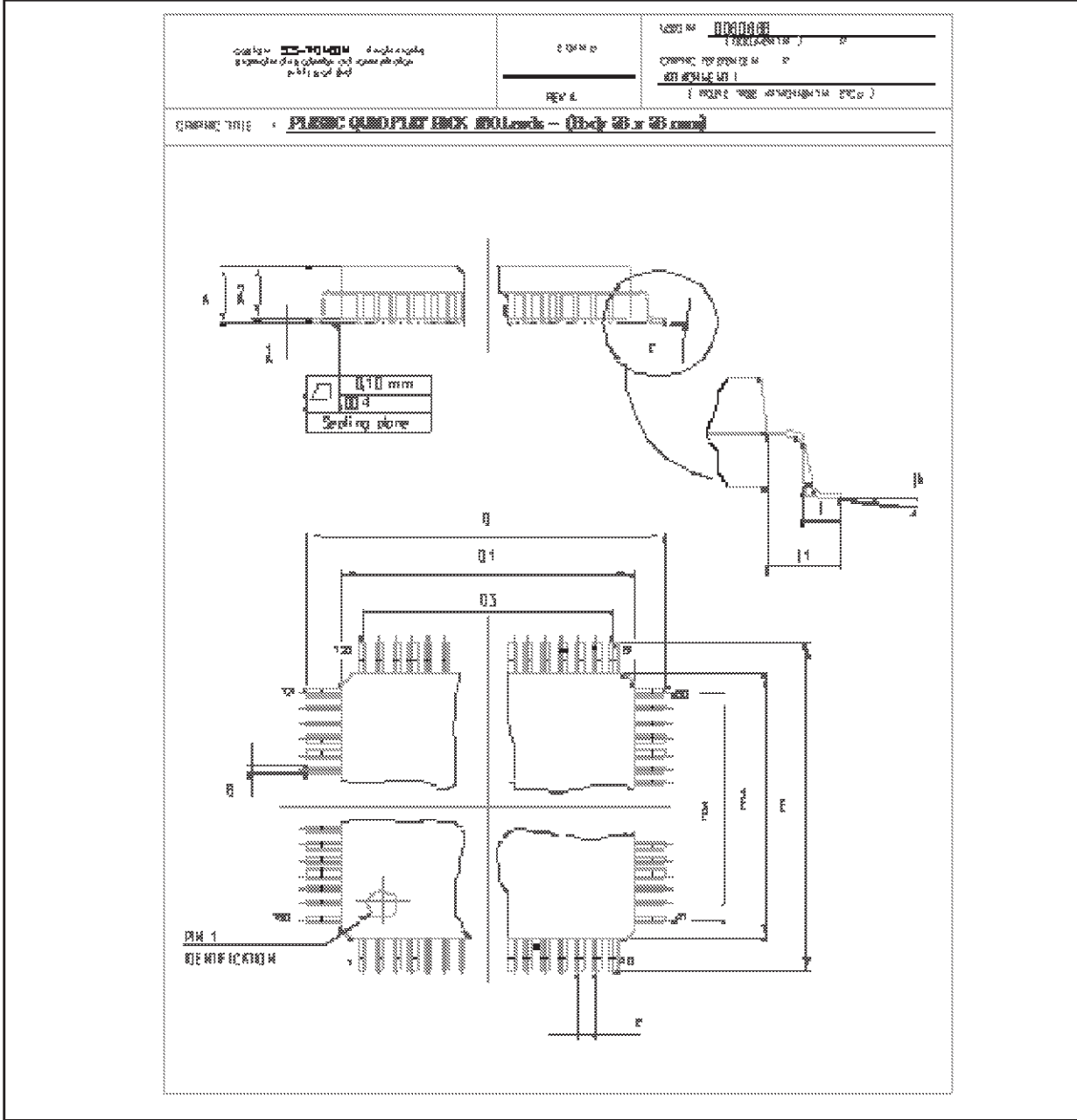

20 DEVICE ID

The identification code for the ST18-AU1 is #*m*52BD041, where *m* is a manufacturing revision number reserved by SGS-THOMSON.

bit 31																														bit 0									
Mask rev					ST18 family					Variant					SGS-THOMSON manufacturers id										1)														
reserved	0	1	0	1	0	0	1	0	1	0	1	1	1	1	0	1	0	0	0	0	0	0	1	0	0	0	0	0	0	1									
	5					2		B			D		0				4				1																		

1) Defined as 1 in IEEE 1149.1 standard.

21 ORDERING INFORMATION

Device	Package
ST18AU1X??S	160 pin plastic quad flat pack (PQFP)

For further information contact your local SGS-THOMSON sales office.

Information furnished is believed to be accurate and reliable. However, SGS-THOMSON Microelectronics assumes no responsibility for the consequences of use of such information nor for any infringement of patents or other rights of third parties which may result from its use. No license is granted by implication or otherwise under any patent or patent rights of SGS-THOMSON Microelectronics. Specifications mentioned in this publication are subject to change without notice. This publication supersedes and replaces all information previously supplied. SGS-THOMSON Microelectronics products are not authorized for use as critical components in life support devices or systems without the express written approval of SGS-THOMSON Microelectronics.

©1997 SGS-THOMSON Microelectronics - All rights reserved.

SGS-THOMSON Microelectronics Group of Companies

Australia - Brazil - Canada - China - France - Germany - Italy - Japan - Korea - Malaysia - Malta - Morocco - The Netherlands - Singapore - Spain - Sweden - Switzerland - Taiwan - Thailand - United Kingdom - U.S.A.